



HOKKAIDO UNIVERSITY

Title	Meteorological Classification of Natural Snow Crystals
Author(s)	MAGONO, Choji; Chung, Woo, Lee
Citation	Journal of the Faculty of Science, Hokkaido University. Series 7, Geophysics, 2(4): 321-335
Issue Date	1966-11-
DOI	
Doc URL	http://hdl.handle.net/2115/8672
Right	
Type	bulletin
Additional Information	
File Information	2(4)_p321-335.pdf



[Instructions for use](#)

Meteorological Classification of Natural Snow Crystals

Choji MAGONO and Chung Woo LEE

(Received Aug. 23, 1966)

Abstract

From a meteorological point of view, Nakaya's classification of natural snow crystals was modified and supplemented. By this improvement of the classification, the certain inconveniences in the description of crystal shapes of natural snow crystals were removed, particularly in unsymmetrical or irregular shapes.

By the use of this improved classification, the temperature and vapor supply conditions for the growth of various kinds of natural snow crystals were described. The conditions were determined by meteorological observation methods. It may be seen that the conditions are very similar to Nakaya's T_a-s diagram. This means that the Nakaya's diagram is applicable to the formation of natural snow crystals.

1. Introduction

Nakaya's¹⁾ general classification of snow crystals was a most perfect classification for natural snow crystals from a physical point of view, and the result of his investigation of the artificial snow crystals, namely, the T_a-s diagram was described by the classification method. Gold and Power²⁾, Murai³⁾ and Grunow^{4), 5)} reported that Nakaya's diagram was roughly applicable to the formation of natural snow crystals.

The diagram was further studied and improved by Nakaya, Hanajima and Muguruma⁶⁾, Hallett and Mason⁷⁾ and Kobayashi^{8), 9), 10)}. With these improvements, it may be expected that there is a possibility that the present improved diagram will be useful as a more exact and detailed indicator of temperature and humidity of a cloud in which snow crystals are formed.

In the recent ten years, Magono and his colleagues^{11), 12), 13)} continued their observation of natural snow crystals in Hokkaido from a meteorological point of view. At first Nakaya's classification method to describe the shape of snow crystals was used, but they found that his classification was insufficient to describe the meteorological difference in the type of snow crystals, because the classification was too simple in the group of unsymmetric or modified types, although it is in good detail in the group of regular types. In actual cases, most of snow crystals are irregular, unsymmetric, modified or rimed.

Table 1. Meteorological classification of snow crystals

		Names	Plate No.			
N	Needle crystal	1. Simple needle	a. Elementary needle	1		
			b. Bundle of elementary needles	1		
			c. Elementary sheath	2		
		2. Combination of needle crystals	d. Bundle of elementary sheaths	2		
			e. Long solid column	3		
			a. Combination of needles	1		
C	Columnar crystal	1. Simple column	b. Combination of sheaths	2		
			c. Combination of long solid columns	3		
			a. Pyramid	3		
			b. Cup	4		
			c. Solid bullet	4		
			d. Hollow bullet	4		
			e. Solid column	5		
			f. Hollow column	5		
			g. Solid thick plate	6		
		h. Thick plate of skeleton form	6			
		i. Scroll	6			
		2. Combination of columns	a. Combination of bullets	4		
			b. Combination of columns	5		
		P	Plane crystal	1. Regular crystal developed in one plane	a. Hexagonal plate	7
					b. Crystal with sectorlike branches	7
					c. Crystal with broad branches	7
					d. Stellar crystal	8
					e. Ordinary dendritic crystal	8
f. Fernlike crystal	8					
2. Plane crystal with extensions of different form	a. Stellar crystal with plates at ends			9		
	b. Stellar crystal with sectorlike ends			9		
	c. Dendritic crystal with plates at ends			9		
	d. Dendritic crystal with sectorlike ends			9		
	e. Plate with simple extensions			10		
	f. Plate with sectorlike extensions			10		
	g. Plate with dendritic extensions			10		
3. Crystal with irregular number of branches	a. Two-branched crystal			11		
	b. Three-branched crystal			11		
	c. Four-branched crystal			11		
4. Crystal with 12 branches	a. Broad branch crystal with 12 branches			12		
	b. Dendritic crystal with 12 branches			12		
5. Malformed crystal	Many varieties	12				
6. Spatial assemblage of plane branches	a. Plate with spatial plates	13				
	b. Plate with spatial dendrites	13				
	c. Stellar crystal with spatial plates	14				
	d. Stellar crystal with spatial dendrites	14				
7. Radiating assemblage of plane branches	a. Radiating assemblage of plates	15				
	b. Radiating assemblage of dendrites	15				

Table 1. (continued)

		Names	Plate No.		
CP	Combination of column and plane crystals	1. Column with plane crystals at both ends	a. Column with plates	16	
			b. Column with dendrites	16	
			c. Multiple capped column	16	
		2. Bullet with plane crystals	a. Bullet with plates	17	
			b. Bullet with dendrites	17	
		3. Plane crystal with spatial extensions at ends	a. Stellar crystal with needles	18	
			b. Stellar crystal with columns	18	
			c. Stellar crystal with scrolls at ends	18	
			d. Plate with scrolls at ends	18	
		S	Columnar crystal with extended side planes	1. Side planes	19
				2. Scalelike side planes	19
				3. Combination of side planes, bullets and columns	19
R	Rimmed crystal (crystal with cloud droplets attached)	1. Rimmed crystal	a. Rimmed needle crystal	20	
			b. Rimmed columnar crystal	20	
			c. Rimmed plate or sector	21	
			d. Rimmed stellar crystal	21	
		2. Densely rimmed crystal	a. Densely rimmed plate or sector	22	
			b. Densely rimmed stellar crystal	22	
			c. Stellar crystal with rimmed spatial branches	22	
		3. Graupellike snow	a. Graupellike snow of hexagonal type	23	
			b. Graupellike snow of lump type	23	
			c. Graupellike snow with nonrimmed extensions	23	
		4. Graupel	a. Hexagonal graupel	24	
			b. Lump graupel	24	
			c. Conelike graupel	24	
		I	Irregular snow crystal	1. Ice particle	25
				2. Rimmed particle	25
				3. Broken piece from a crystal	a. Broken branch
b. Rimmed broken branch	25				
4. Miscellaneous	25				
G	Germ of snow crystal (ice crystal)	1. Minute column	26		
		2. Germ of skelton form	26		
		3. Minute hexagonal plate	26		
		4. Minute stellar crystal	27		
		5. Minute assemblage of plates	27		
		6. Irregular germ	27		







































	N1a Elementary needle		C1f Hollow column		P2b Stellar crystal with sectorlike ends
	N1b Bundle of elementary needles		C1g Solid thick plate		P2c Dendritic crystal with plates at ends
	N1c Elementary sheath		C1h Thick plate of skelton form		P2d Dendritic crystal with sectorlike ends
	N1d Bundle of elementary sheaths		C1i Scroll		P2e Plate with simple extensions
	N1e Long solid column		C2a Combination of bullets		P2f Plate with sectorlike extensions
	N2a Combination of needles		C2b Combination of columns		P2g Plate with dendritic extensions
	N2b Combination of sheaths		P1a Hexagonal plate		P3a Two-branched crystal
	N2c Combination of long solid columns		P1b Crystal with sectorlike branches		P3b Three-branched crystal
	C1a Pyramid		P1c Crystal with broad branches		P3c Four-branched crystal
	C1b Cup		P1d Stellar crystal		P4a Broad branch crystal with 12 branches
	C1c Solid bullet		P1e Ordinary dendritic crystal		P4b Dendritic crystal with 12 branches
	C1d Hollow bullet		P1f Fernlike crystal		P5 Malformed crystal
	C1e Solid column		P2a Stellar crystal with plates at ends		P6a Plate with special plates

Fig. 1. Meteorological classification of snow crystals, sketches









































	P6b Plate with spatial dendrites		CP3d Plate with scrolls at ends		R3c Graupellike snow with nonrimed extensions
	P6c Stellar crystal with spatial plates		S1 Side planes		R4a Hexagonal graupel
	P6d Stellar crystal with spatial dendrites		S2 Scalelike side planes		R4b Lump graupel
	P7a Radiating assemblage of plates		S3 Combination of side planes, bullets and columns		R4c Conelike graupel
	P7b Radiating assemblage of dendrites		R1a Rimed needle crystal		I1 Ice particle
	CP1a Column with plates		R1b Rimed columnar crystal		I2 Rimed particle
	CP1b Column with dendrites		R1c Rimed plate or sector		I3a Broken branch
	CP1c Multiple capped column		R1d Rimed stellar crystal		I3b Rimed broken branch
	CP2a Bullet with plates		R2a Densely rimed plate or sector		I4 Miscellaneous
	CP2b Bullet with dendrites		R2b Densely rimed stellar crystal		G1 Minute column
	CP3a Stellar crystal with needles		R2c Stellar crystal with rimed spatial branches		G2 Germ of skeleton form
	CP3b Stellar crystal with columns		R3a Graupellike snow of hexagonal type		G3 Minute hexagonal plate
	CP3c Stellar crystal with scrolls at ends		R3b Graupellike snow of lump type		G4 Minute stellar crystal
					G5 Minute assemblage of plates
					G6 Irregular germ

Fig. 1. (continued)



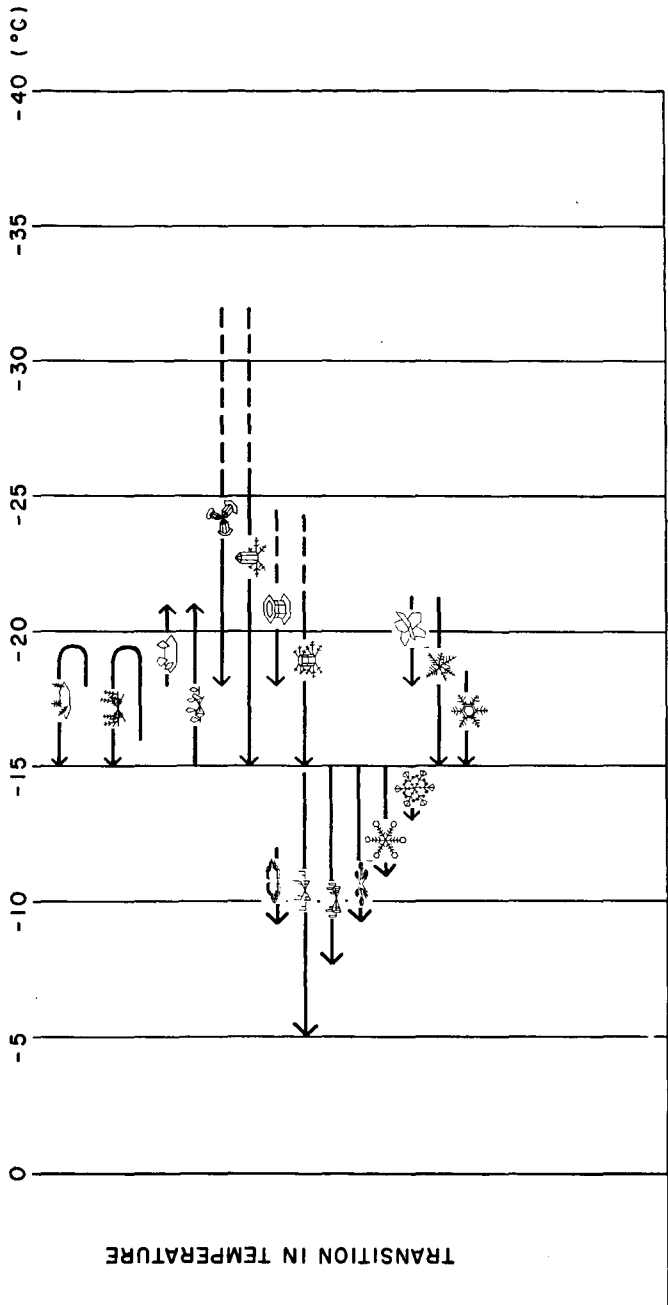
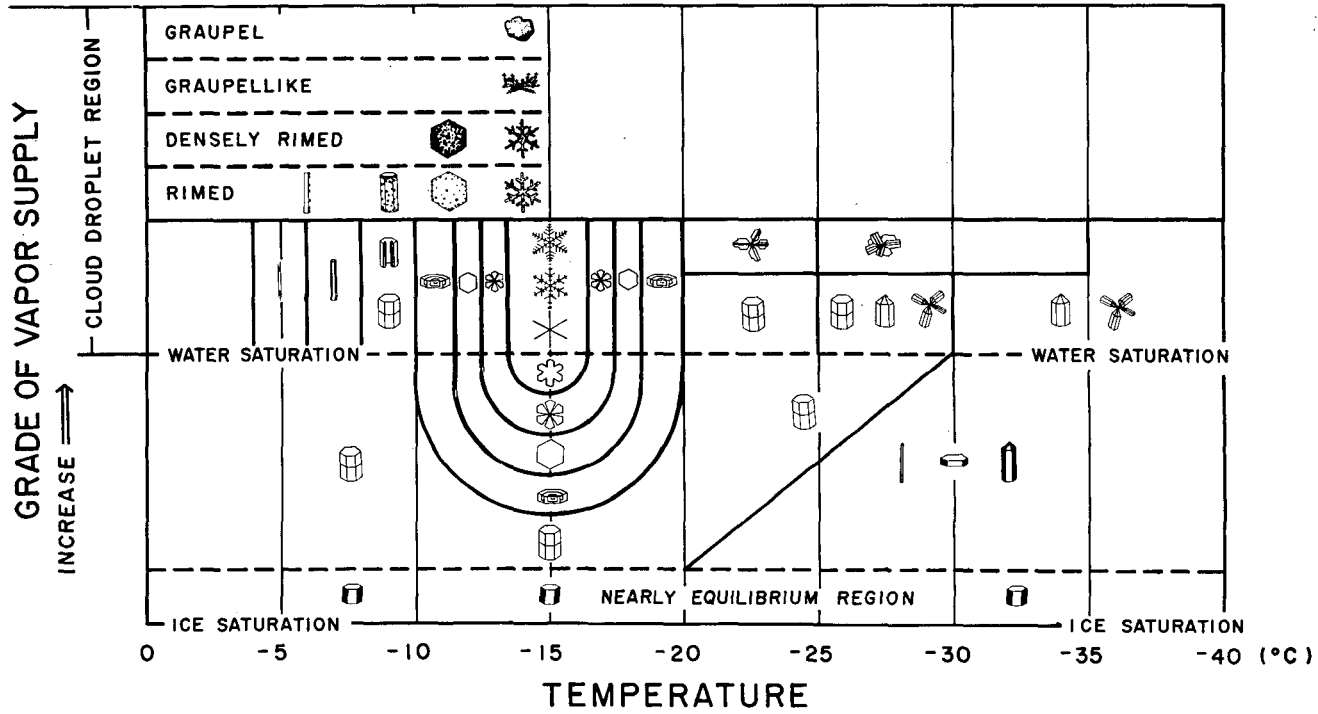

Fig. 2. Temperature and humidity conditions for the growth of natural snow crystals of various types

Several years ago, the authors undertook to improve Nakaya's classification method with his agreement, and recently they arrived at a fairly satisfactory meteorological classification method by several modifications and supplements of his classification.

The authors undertook to determine also the temperature and humidity conditions for the formation of various kinds of natural snow crystals by the use of purely meteorological methods. The conditions will be described later. One will find that the conditions are quite similar to Nakaya's T_d - s diagram.

2. General classification of natural snow crystals from a meteorological point of view

In order to remove the inconvenience in the description of the type of natural snow crystals, some parts of Nakaya's classification were modified and some classifications were added according to the result of laboratory experiments described above and the result of meteorological observation. Thus the number of classification increased from 36 to 80 classes which is listed in Table 1. In the table, the corresponding numbers of plates of microscopic photographs are shown at the right end. And the shape of snow crystals of each class are shown schematically in Fig. 1, and illustrated by microscopic photographs at the end of this paper.

The modifications and supplements for Nakaya's classification are explained below.

3. Modifications and supplements

In order to remove the inconvenience in the description of the type of natural snow crystals, the following modifications and supplements were made.

3.1 Supplement of sheath type crystals

There are microscopically three kinds of needlelike snow crystals, although they visually seem to belong to the same kind. The first is the needlelike crystal with knife edge shape tops, the second is the extremely thin hollow column, and the last is the extremely thin solid column.

The first was classified as "needle crystals" by Nakaya, but the second was not clearly classified. However, the snow crystals of the second type were shown in the results of laboratory experiment by Hallett and Mason, Kobayashi, and Nakaya, Hanajima and Muguruma, and were observed in natural snow crystals as reported by Magono and his colleagues¹¹⁾. There-

fore the second type was classified as a "sheath" as seen in N1c, N1d and N2b in Table 1. The snow crystals of sheath type are formed in the temperature range between -6 and -8°C and the snow crystals of the original needle type are formed in the temperature range between -4 and -6°C , as seen in Fig. 2.

Shimizu¹⁴⁾ found snow crystals of solid thin column type, namely the third type in the Antarctica. The snow crystals of this type have an outward appearance similar to the second type, but the temperature condition of the third type is quite different from that of the sheath. According to Shimizu's observation they were formed at a temperature range colder than -30°C . Recently Kobayashi¹⁵⁾ obtained such solid columns experimentally around -50°C . The meteorological meaning for the difference between hollow and solid columns is stated below.

3.2 *Distinction between solid columns and hollow columns*

Most of columnar crystals which are observed, are hollow ones, in other words, are of skelton form. However Kobayashi^{9),10)} found that solid columns were easily obtained artificially in nearly supersaturated conditions over a wide temperature range. In addition to that, minute solid columnar crystals are frequently observed in the early stage of mature columnar crystals.

From the theory of crystal growth, it may be considered that snow crystals develop into solid columnar form under a nearly equilibrium state, and into hollow columnar forms under a considerably supersaturated condition. Therefore the distinction between solid and hollow columns is important meteorologically. In the present classification, all columnar crystals (needles, columns, bullets and thick plates) were further divided into solid and hollow types, as seen in Table 1.

3.3 *Distinction between columns and thick plates*

In Nakaya's classification, the term "thick plates" are used for two types, namely short columns and densely rimed plane crystals. In the present classification, the latter is named "densely rimed crystals", in order to avoid confusion.

In the nomenclature, it would be better to have a clear criterion to distinguish the thick plates from the columns. After Zamorsky¹⁶⁾ and Higuchi¹⁷⁾, the ratio of the length to the diameter of a column ranges from 0.5 to 0.8 in the nearly equilibrium state. However in the present classification, columns are called a thick plate when its length is shorter than its

diameter, in the usual sense.

Snow crystals of cup or scroll type are frequently observed in frost and in artificial snow crystals. However, the snow crystals of these types are hardly ever observed in natural snow. The Cloud Physics Group of Hokkaido University took about 30,000 microscopic photographs of natural snow crystals during the recent 10 years, but no cup type crystals were found.

3.4 *Supplement of plane crystals with extensions of different forms*

Plane crystals with extensions of forms different from the center part indicate that the crystals suffered a change in temperature and humidity during their fall. Therefore such a change in form of branches is an important indicator from a meteorological point of view. In the present classification, the changes in the crystal form; from dendrite to sectors, from dendrites to plates are noted and a group was supplied as seen in P2 of Table 1.

3.5 *Crystals with an irregular number of branches*

In Nakaya's classification, snow crystals of plane type were classified in detail, however two-branched, three-branched, four-branched and twelve-branched crystals are assumed to be formed under the same meteorological conditions, because they commonly have two center nuclei and their differences in the numbers of branches are only due to the accidental manner of the distribution of branches to the two center nuclei.

3.6 *Detailed classification of snow crystals of spatial types*

When snow crystals of plane type pass through a cold air layer around -20°C , spatial extensions develop on their basal plane, although the reason is not understood. Because this phenomenon usually occurs when plane snow crystals fall through a temperature inversion layer, the snow crystals of this type are very important as an indicator of the existence of a temperature inversion layer. It is also possible to estimate the height of the inversion from the type of branches of the snow crystals of this type. In the present classification, snow crystals of this type were classified into four groups, considering the forms of both branches and basal planes, as seen in P6 of Table 1.

Snow crystals of radiating type were also divided into two groups from the same point of view, as seen in P7 of Table 1. The snow crystals of radiating type are assumed to originate near -20°C .

3.7 *Supplement of snow crystals with spatial extensions at the ends*

Nakaya classified this combination of columns and plane crystals as one

group. As will be described later, snow crystals of plane type have spatial extensions parallel to the *c*-axis at the ends of their branches when they rapidly fall into a warmer cloud layer around -10°C , therefore this spatial extension at the ends of branches are important meteorologically. Therefore snow crystals of this type were classified as another group, as seen in CP3 of Table 1.

3.8 *Columnar crystals with extended side plane*

So called "powder snow particles" which are often found in cold temperatures lower than -20°C , are composed from a combination of columns and side planes. The snow crystals of this type were classified into three groups, namely "side planes"; "scalelike side planes" and a "combination of side planes, bullets and columns", as seen in S1, S2 and S3 of Table 1.

After Weickmann's observation²⁰), it appears that the latter two groups are formed in temperature regions colder than the former one, namely between -25 and -35°C as described in Fig. 2.

3.9 *Supplement of rimed snow crystal*

In Japan, most of snow crystals are more or less rimed. Therefore the grade of riming is very important. Nakaya classified this type into three groups, namely rimed crystals, graupellike snow, and graupel. The authors added an additional group between the rimed crystals and the graupellike snow, which will be called "densely rimed crystals". This group was named thick plates in Nakaya's classification.

3.10 *Detailed classification of irregular snow crystals*

For the practical recording of the forms of natural snow crystals, the description of irregular crystals is very inconvenient, because Nakaya's classification was too rough in this irregular shape, while the percentage of occurrence of such irregular crystals is much higher than expected.

The authors therefore added two groups, namely "rimed particles" and "broken pieces from a crystal" as described in I2 and I3 of Table 1. The broken pieces may be useful as an indicator of the existence of a strong wind or strong turbulence in a layer below the snow cloud.

3.11 *Supplement of the type of early stage*

Minute snow crystals in the early stage were frequently observed at the summit of Mt. Teine and were sampled by the snow crystal sondes designed by Magono and Tazawa¹⁸). Because the sampling of such snow crystals in the early stage means that these crystals were formed just near

the sampling point, it is desirable to distinguish them from usual mature snow crystals which fall from above.

In the present classification, one group was added as the "germ of snow crystals" for the snow crystals in the early stage, and this group was divided further into six fine classes, namely minute columns: G1, germs of skelton form: G2, minute hexagonal plates: G3, minute stellar crystals: G4, minute assemblage of plates: G5, and irregular germs: G6. The germ of snow crystals are assumed to be the next stage of ice crystals.

4. Conditions for the formation of various kinds of natural snow crystals

The first purpose of the observation of the Cloud Physics Group, Hokkaido University was to examine whether Nakaya's T_a-s diagram was exactly applicable to the formation of natural snow crystals or not.

The examination was made by comparing the crystal shapes with the meteorological condition of the mother cloud in which the snow crystals were formed. Because snow crystals fall from above, an exact comparison required both an observation of the shape of the ends of the branches of snow crystals and a measurement of meteorological conditions of the air parcel in which the snow crystals were sampled. The latter measurement was carried out by the use of five surface observation points distributed vertically at Mt. Teine. The result by this method was reported by one of the authors¹⁹⁾.

However by such methods, only data at fairly lower levels, namely lower than 1,000 m height were obtained. In order to obtain data at higher levels, the data of usual radio sonde soundings which were made by Sapporo Meteorological Observatory were used only when the existence of a cloud layer was confirmed by other methods. Furthermore the results of Weickmann's observation²⁰⁾ of ice crystals in cirrus clouds were used. In the later observation of this work, the snow crystal sondes were used.

By the methods described above, the air temperature of a mother cloud in which the snow crystals were formed as determined fairly exactly; however the determination of humidity was difficult. As well known it is impossible to measure the humidity of supersaturated air by the use of a usual hygrometer or a psychrometer, and it is also difficult to obtain the exact value of humidity in cold temperature. However the meters measuring the humidity were reliable as an indicator to determine whether the air was saturated or not with respect to an ice surface. Therefore it was possible to determine the

thickness of a cloud layer in which the humidity is assumed to be higher than at least the saturation value with respect to the ice surface. Accordingly the temperature of the mother cloud was reliable but the exact humidity was not obtained. Estimations were limited to whether the vapor supply was sufficient or insufficient by considering whether the air in the mother cloud was apparently saturated with respect to a water surface or with respect to an ice surface.

By the procedures described above, the conditions for the formation of various kinds of natural snow crystals were obtained as shown in Fig. 2. In the figure, the horizontal axis shows the air temperature in which snow crystals of the corresponding types are formed, and the vertical axis shows a rough estimation of grade of vapor supply for the growth of snow crystals. The authors consider that the cloud droplets are an important source of vapor supply. The crystal shapes of snow crystals are shown schematically at the center of the corresponding area in the condition chart. The group of rimed snow crystals are given in the left middle part, and the groups corresponding to the temperature transition are given at the upper part. The groups at the top correspond to the type of snow crystals which fall through a temperature inversion layer.

One sees that this chart is similar to Nakaya's T_a - s diagram which was obtained by laboratory experiments, however the information about air temperature is more detailed. It will be also seen that the greater the grade of vapor supply, the more complex the form of branches.

In making this chart, the authors strongly felt that the data of temperature in regions colder than -20°C were quite insufficient. It is further desirable to investigate the snow crystal habits in such cold regions as given in Kobayashi's study¹⁵⁾.

Acknowledgements:

The modification and supplement for Nakaya's classification of snow crystals were carried out from a practical necessity to describe the shapes of natural snow crystals in detail, and this improvement was based on the results of laboratory experiments and of the meteorological observation made by our group. It is believed that this new classification is sufficient to describe the microscopic shapes of natural snow crystals. The authors would have liked to ask Dr. Nakaya's opinion on the present modifications and revisions, but unfortunately Dr. Nakaya passed on before we could finish this work. The

team deeply mourns his passing but still holds him in the highest respect.

This work was made possible by the use of about thirty thousands microscopic photographs of snow crystals which were taken by the members of the Cloud Physics Group; Drs. D. Kuroiwa, T. Kobayashi, T. Okita, K. Itagaki, K. Higuchi, K. Orikasa, G. Wakahama, J. Muguruma, T. Takahashi, K. Kikuchi, T. Nakamura and 23 students who were in our laboratory. The authors wish express their gratitude to our colleagues. Finally they also wish to thank Dr. Shimizu who offered his microscopic photographs of ice crystals in Antarctica.

This work was supported by the Educational Ministry of Japan and supported partially by National Science Foundation.

References

- 1) NAKAYA, U.: Snow Crystal, natural and artificial. Harvard Univ. Press (1954) 76.
- 2) GOLD, L.W. and B.W. POWER: Dependence of the forms of natural snow crystals on meteorological conditions. *Jour. Met.*, **11** (1954) 35-42.
- 3) MURAI, G.: The relation between the crystal type of falling snow particles and the meteorological conditions of the upper air layer (in Japanese). *Teionkagaku*, Ser. A, **15** (1956) 13-32.
- 4) GRUNOW, J.: Observation and analysis of snow crystals for producing the suitability as aerological sonde, I. Contract No. DA-91-591-EUC-1030 (1959).
- 5) GRUNOW, J.: *Ibid*, II (1960).
- 6) NAKAYA, U., M. HANAJIMA and J. MUGURUMA: Physical investigations on the growth of snow crystals. *Jour. Fac. Sci., Hokkaido Univ.*, Ser. II, **5** (1958) 87-118.
- 7) HALLETT, J. and B.J. MASON: The influence of temperature and supersaturation on the habit of ice crystals grown from the vapor. *Proc. Roy. Soc., A*, **247** (1958) 440-453.
- 8) KOBAYASHI, T.: On the habit of snow crystals artificially produced at low pressures. *Jour. Met. Soc. Jap.*, Ser. II, **36** (1958) 193-208.
- 9) KOBAYASHI, T.: Experimental researches on the snow crystal habit and growth by means of a diffusion cloud chamber. *Jour. Met. Soc. Jap.*, 75th Ann. Vol., (1957) 38-47.
- 10) KOBAYASHI, T.: The growth of snow crystals at low supersaturations. *Phil. Mag.*, **6** (1961) 1363-1370.
- 11) MAGONO, C. and colleagues: Preliminary investigation on the growth of natural snow crystals by the use of observation points distributed vertically. *Jour. Fac. Sci., Hokkaido Univ.*, Ser. VII (Geophysics), **1** (1959) 195-211.
- 12) MAGONO, C. and colleagues: Investigation on the growth and distribution of natural snow crystals by the use of observation points distributed vertically, II. *Jour. Fac. Sci., Hokkaido Univ.*, Ser. VII, **1** (1960) 267-282.
- 13) MAGONO, C. et al: *Ibid*. III, *Ibid* (1962) 375-391.
- 14) SHIMIZU, H.: "Long prism" crystals observed in the precipitation in Antarctica. *Jour. Met. Soc. Jap.*, Ser. II, **41** (1963) 305-307.

- 15) KOBAYASHI, T.: Vapour growth of ice crystal between -40 and -90°C . Jour. Met. Soc. Jap., Ser. II, **43** (1965), 359-367.
- 16) ZAMORSKY, A.D.: Atmosfernyi Led, nej, gololed, sneg i grad, Isdatel'stvo Akademij, Nauk, SSSR. (1955) 249.
- 17) HIGUCHI, K.: On the shape of ice crystals (in Japanese). Jour. Met. Soc. Jap., Ser. II, **39** (1961) 237-248.
- 18) MAGONO, C. and S. TAZAWA: Design of "Snow Crystal Sondes". Jour. Atmos. Sci., **23** (1966) 618-625.
- 19) MAGONO, C.: The temperature conditions for the growth of natural and artificial snow crystals. Jour. Met. Soc. Jap., Ser. II, **40** (1962) 185-192.
- 20) WEICKMANN, H.: The Ice Phase in the Atmosphere. Ministry of Supply, Millbank, London (1948).

雪の結晶の一般分類

名 称		図版 番号	写真番号
N 針状結晶	1. 単なる針	a. 単針	1, 2
		b. 束状針	3, 4
	2. 針状結晶組合せ	c. 単鞘	7, 8
		d. 束状鞘	9, 10
		e. 針状角柱	13, 14
		f. 針組合せ	5, 6
C 角柱状結晶	1. 単なる角柱	b. 鞘組合せ	11, 12
		c. 針状角柱組合せ	15, 16
		a. ビラミッド	3, 17
		b. 盃	4
		c. 無垢砲弾	4, 18, 19
		d. 中空砲弾	20, 21
e. 無垢角柱		5, 24, 25	
f. 中空角柱		5, 26, 27	
g. 無垢厚板		6, 30, 31	
h. 骸晶	6, 32, 33		
i. 渦巻	6, 34, 35		
2. 角柱組合せ	a. 砲弾集合	4, 22, 23	
	b. 角柱集合	5, 28, 29	
P 板状結晶	1. 正規六花	a. 角板	7, 36, 37
		b. 扇形	7, 38, 39
		c. 広巾六花	7, 40, 41
		d. 星状六花	8, 42, 43
		e. 普通樹枝	8, 44, 45
		f. 羊歯状六花	8, 46, 47
	2. 変遷六花	a. 角板付六花	9, 48, 49
		b. 扇形付六花	9, 50, 51
		c. 角板付樹枝	9, 52
		d. 扇形付樹枝	9, 53
		e. 枝付角板	10, 54, 55
		f. 扇形付角板	10, 56, 57
		g. 樹枝付角板	10, 58, 59
	3. 不規則六花	a. 二花	11, 60, 61
		b. 三花	11, 62, 63
		c. 四花	11, 64, 65
	4. 十二花	a. 広巾十二花	12, 66, 67
	5. 畸形	b. 樹枝十二花	12, 68, 69
			12, 70, 71
	6. 立体型	a. 立体扇形付角板	13, 72, 73, 74
		b. 立体樹枝付角板	13, 75, 76, 77
c. 立体扇形付樹枝		14, 78, 79, 80	
d. 立体樹枝付樹枝		14, 81, 82, 83	
7. 放射型	a. 放射角板	15, 84, 85, 86	
	b. 放射樹枝	15, 87, 88, 89	

名 称		図版 番号	写真番号
C P角柱・板状 組合せ	1. 鼓型結晶	a. 角板付角柱	16 90, 91
		b. 樹枝付角柱	16 92, 93
		c. 致々鼓	16 94, 95
	2. 砲弾・板状組合せ	a. 角板付砲弾	17 96, 97
		b. 樹枝付砲弾	17 98, 99
	3. 縁高結晶	a. 針付六花	18 100, 101
		b. 角柱付六花	18 102, 103
		c. 渦巻付六花	18 104
		d. 渦巻付角板	18 105
	S 側面結晶	1. 側面結晶	19 106, 107
2. 鱗型側面結晶		19 108, 109	
3. 側面, 砲弾, 角柱の不規則集合		19 110, 111	
R 雲粒付結晶	1. 雲粒付結晶	a. 雲粒付針状結晶	20 112, 113, 114
		b. 雲粒付角柱状結晶	20 115, 116, 117
		c. 雲粒付角板	21 118, 119, 120
		d. 雲粒付六花	21 121, 122, 123
	2. 濃密雲粒付結晶	a. 濃密雲粒付角板	22 124, 125
		b. 濃密雲粒付六花	22 126, 127
		c. 雲粒付立体六花	22 128, 129
	3. 霰状雪	a. 六花霰状雪	23 130, 131
		b. 塊状霰状雪	23 132, 133
		c. 枝付霰状雪	23 134, 135
	4. 霰	a. 六花霰	24 136, 137
		b. 塊状霰	24 138, 139
c. 紡錘状霰		24 140, 141	
I 不定形	1. 氷粒	25 142	
	2. 雲粒付雪粒	25 143	
	3. 結晶破片	25 144	
	4. その他	枝破片	25 145, 146
		雲粒付破片	25 147
G 初期結晶	1. 小角柱	26 148, 149	
	2. 初期骸晶	26 150, 151	
	3. 小角板	26 152, 153	
	4. 小六花	27 154, 155	
	5. 小角板集合	27 156, 157	
	6. 小不規則結晶	27 158, 159	

Plate 1 Needle crystals; needles

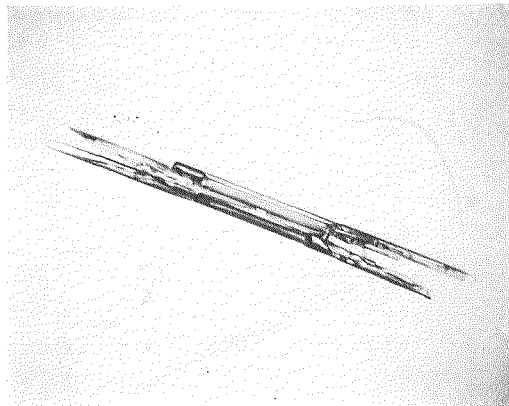

1 N1a Elementary needle × 49

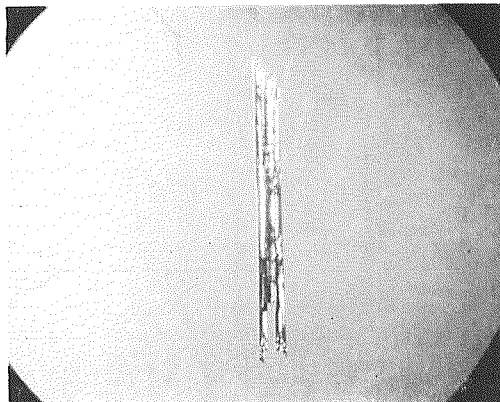

2 N1a Elementary needle × 26

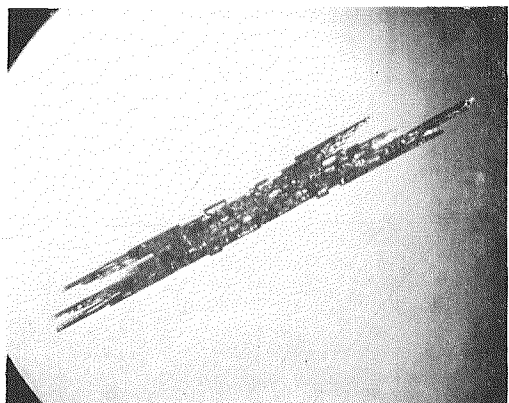

3 N1b Bundle of elementary needles × 28

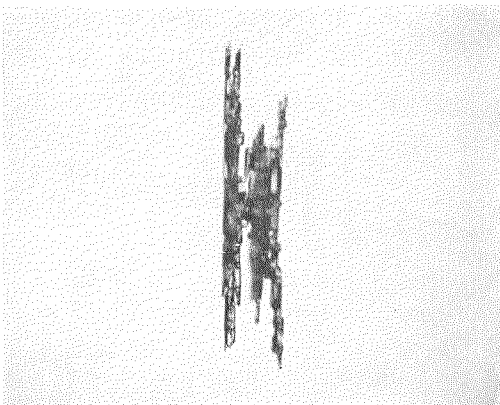

4 N1b Bundle of elementary needles × 35

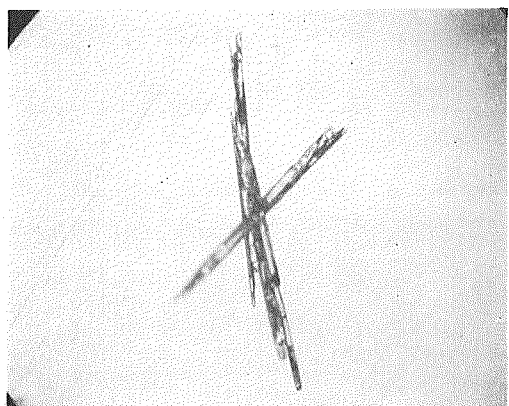

5 N2a Combination of needles × 29



6 N2a Combination of needles × 32

Plate 2 Needle crystals; sheaths

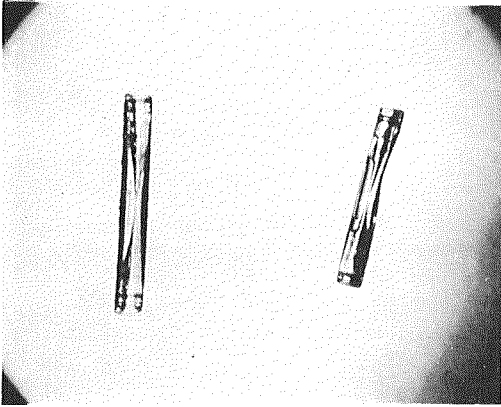

7 N1c Elementary sheaths $\times 37.5$

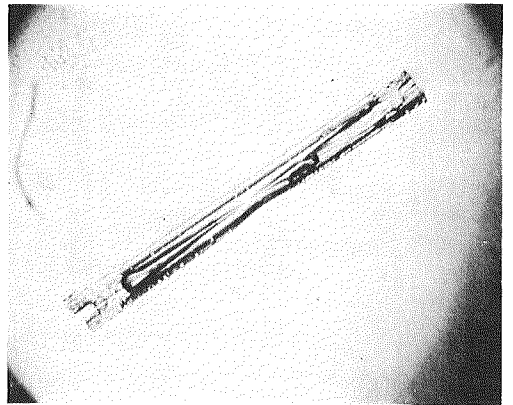

8 N1c Elementary sheath $\times 38$

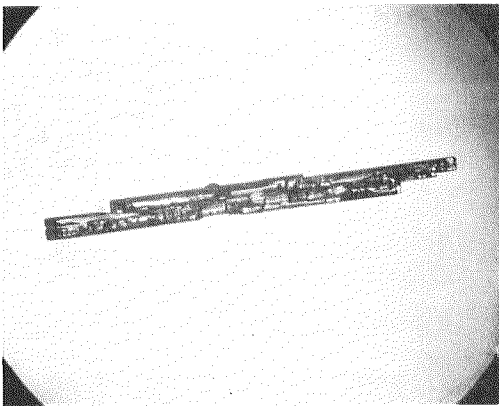

9 N1d Bundle of elementary sheaths $\times 27$

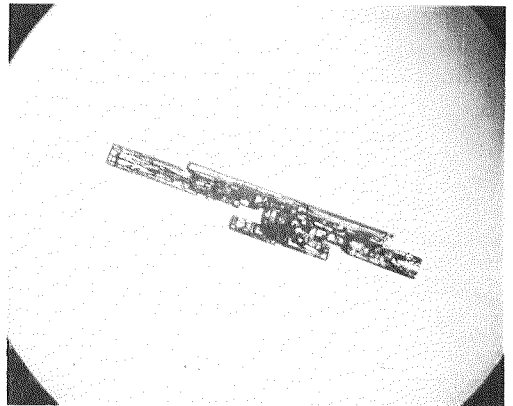

10 N1d Bundle of elementary sheaths $\times 27$

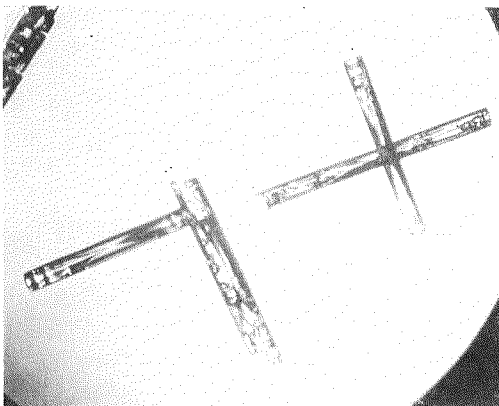

11 N2b Combination of sheaths $\times 27$

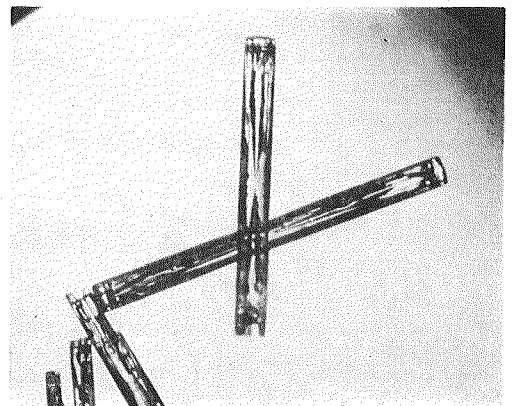

12 N2b Combination of sheaths $\times 31$

Plate 3 Needle crystals: long solid columns and pyramids

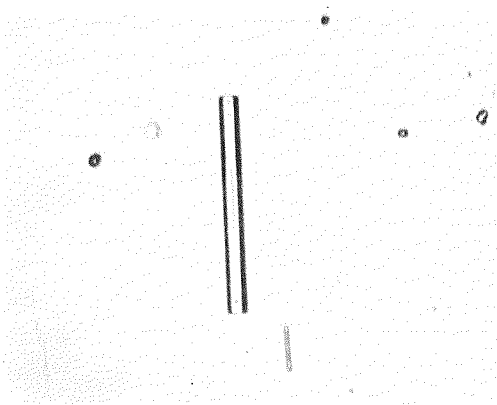

13 N1e Long solid column; after Shimizu
× 69

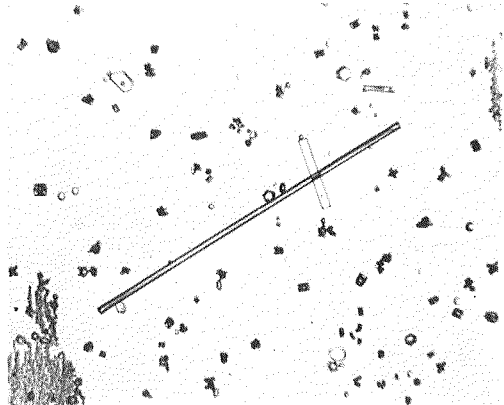

14 N1e Long solid column; after Shimizu
× 40.5

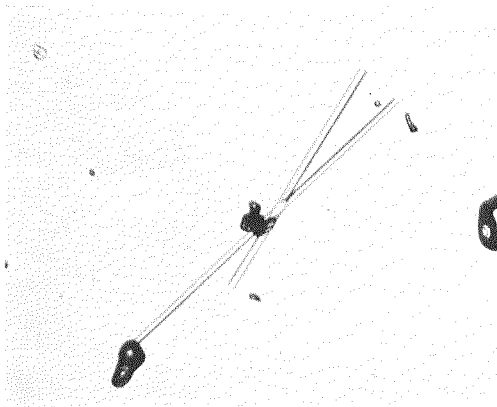

15 N2c Combination of long solid columns;
after Shimizu
× 58

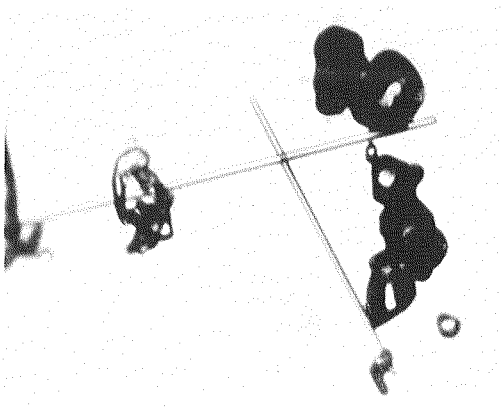

16 N2c Combination of long solid columns;
after Shimizu
× 90

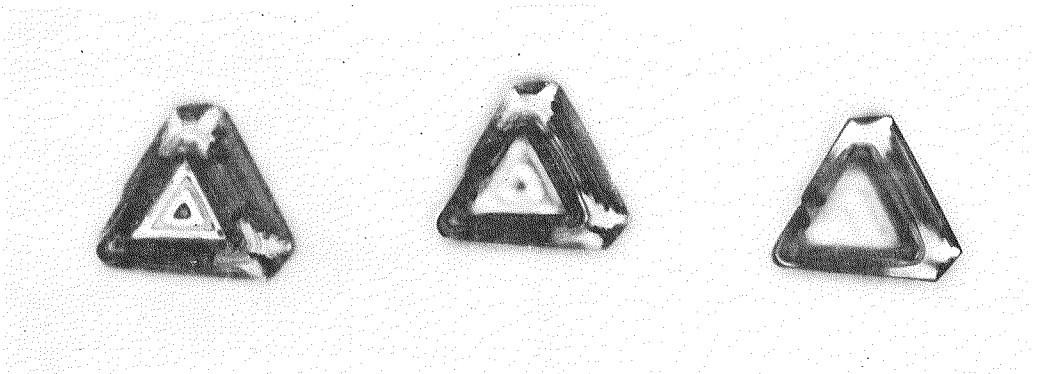

17 C1a Pyramid; focusing on top focusing on middle focusing on bottom × 73.5

Plate 4 Columnar crystals; bullets

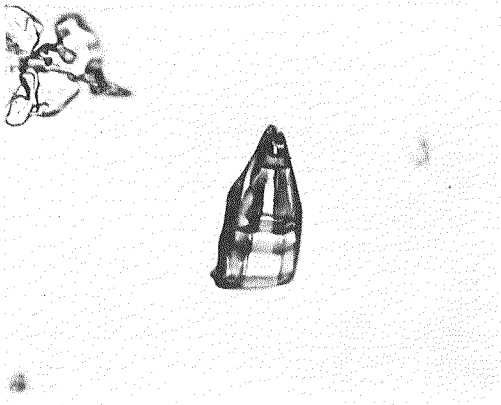

18 C1c Solid bullet $\times 82.5$

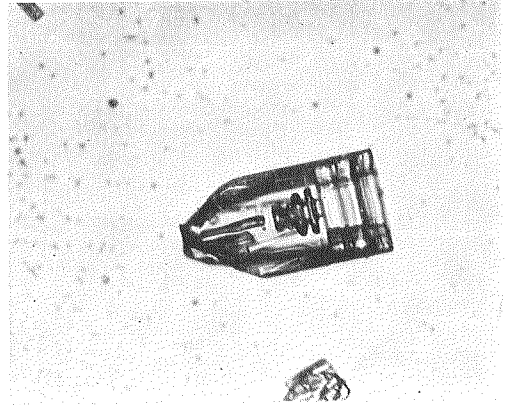

19 C1c Solid bullet $\times 82.5$

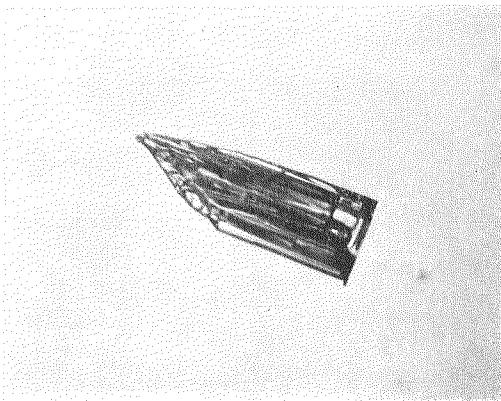

20 C1d Hollow bullet $\times 39$

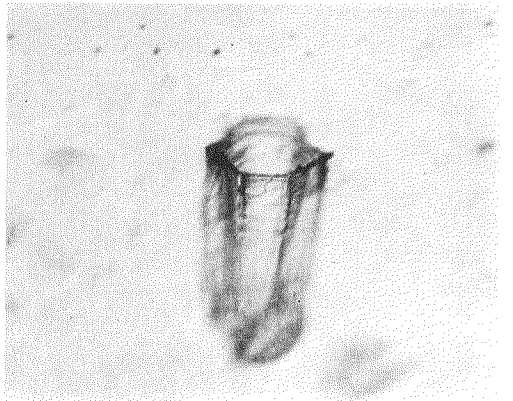

21 C1d Hollow bullet $\times 68$

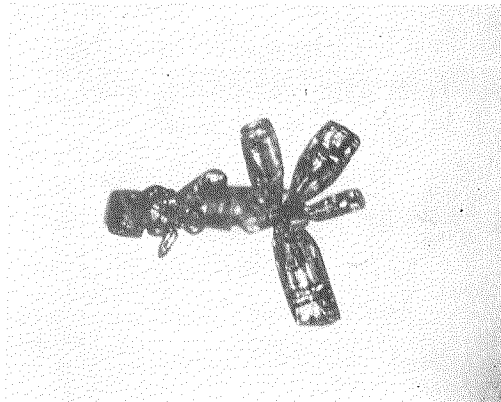

22 C2a Combination of bullets $\times 43$

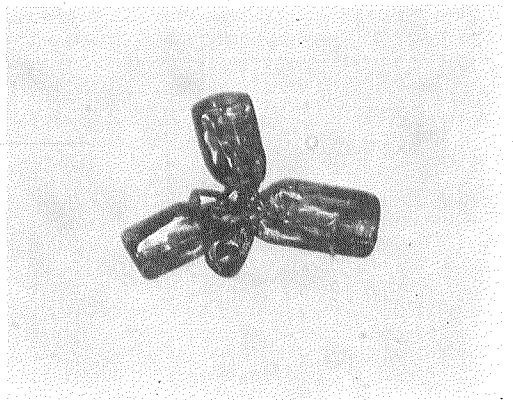

23 C2a Combination of bullets $\times 41$

Plate 5 Columnar crystals; columns

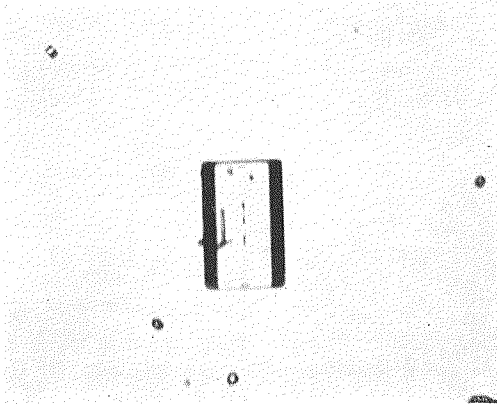

24 C1e Solid column $\times 81$

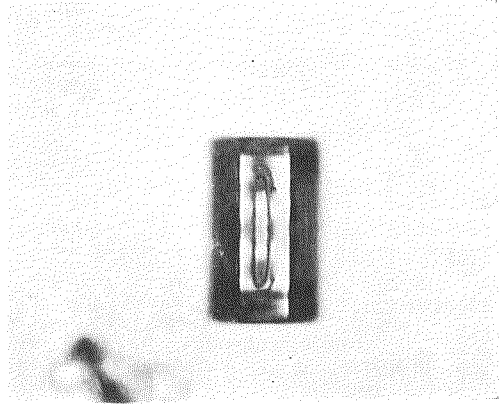

25 C1e Solid column $\times 80.5$

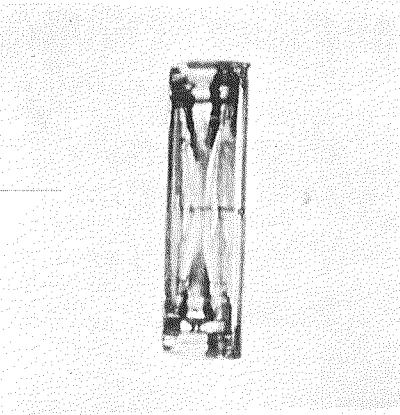

26 C1f Hollow column $\times 52.5$

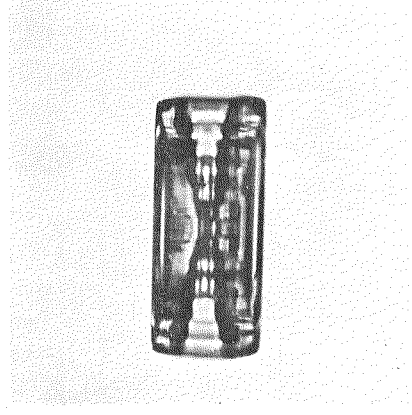

27 C1f Hollow column $\times 73.5$

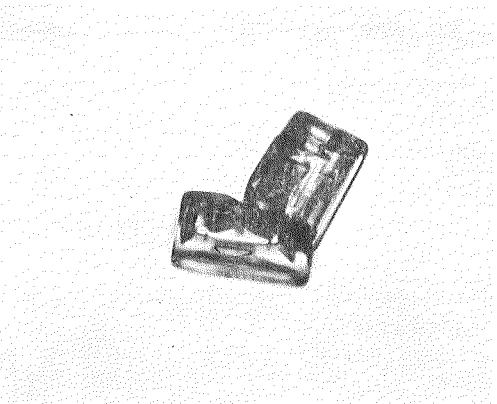

28 C2b Combination of columns $\times 72$

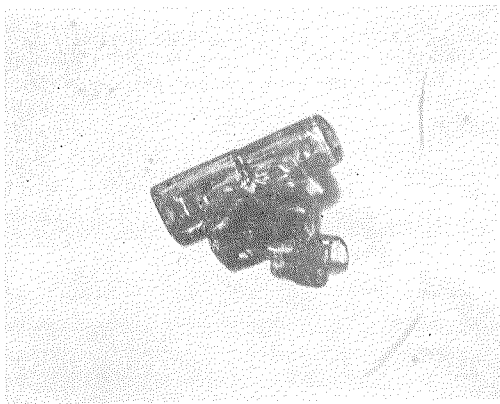

29 C2b Combination of columns $\times 51.5$

Plate 6 Columnar crystals; thick plates and scrolls

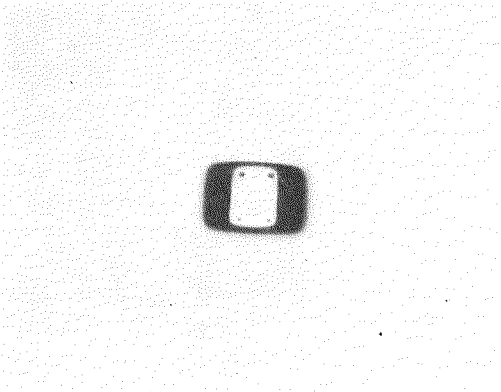

30 C1g Solid thick plate $\times 106$

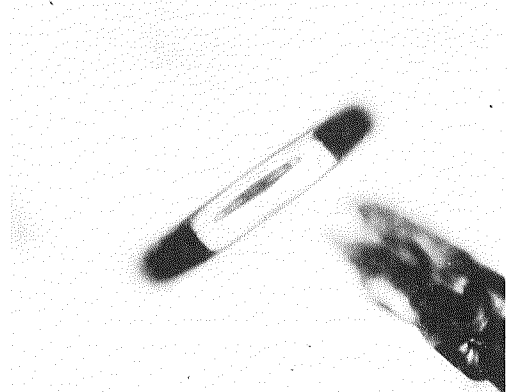

31 C1g Solid thick plate $\times 67.5$

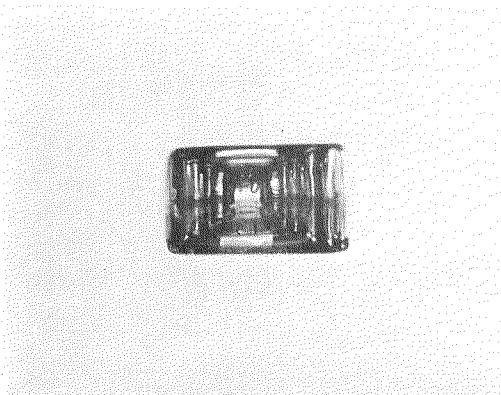

32 C1h Thick plate of skelton form $\times 71$

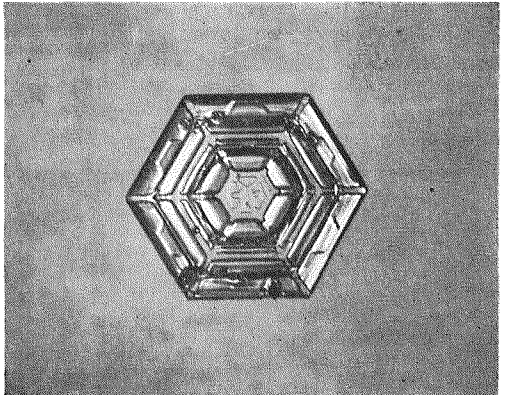

33 C1h Thick plate of skelton form $\times 38$

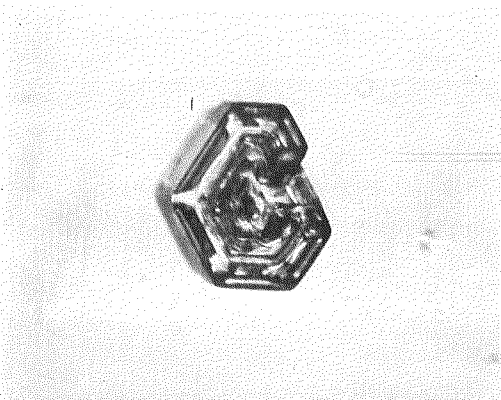

34 C1i Scroll $\times 76$

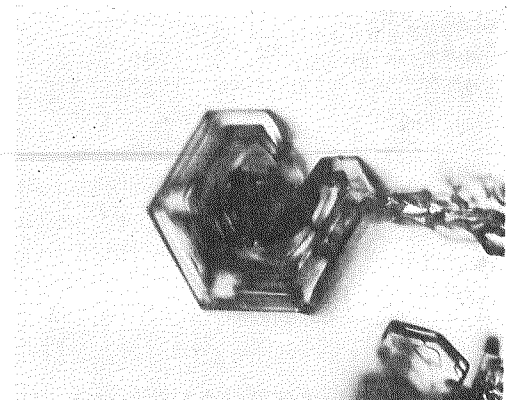

35 C1i Scroll $\times 78$

Plate 7 Plane crystals; plates, sectors and broad branches

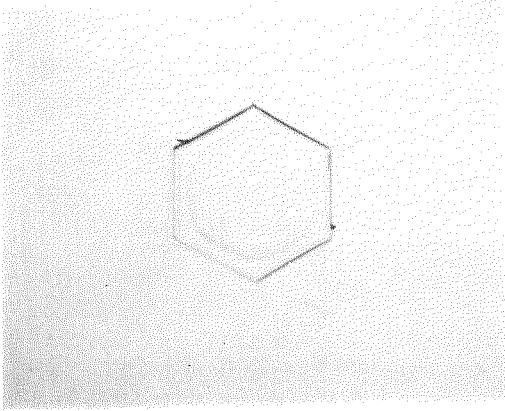

36 P1a Hexagonal plate $\times 34.5$

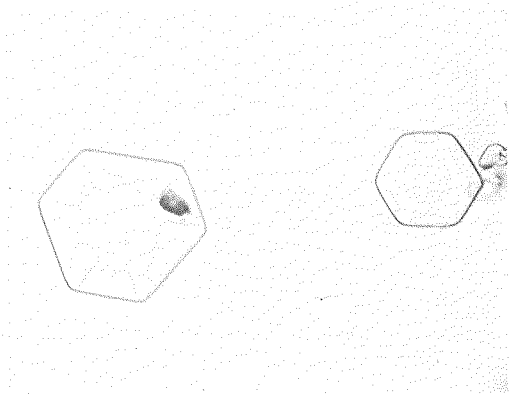

37 P1a Hexagonal plates $\times 46.5$

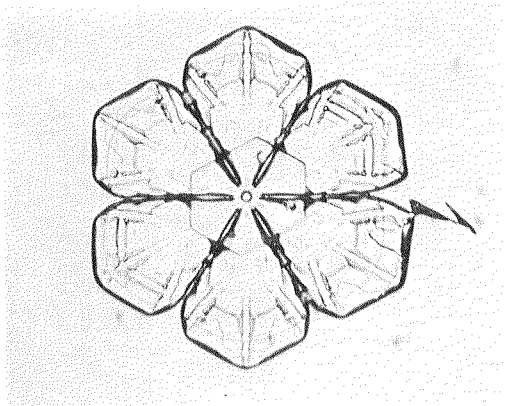

38 P1b Crystal with sectorlike branches $\times 24$

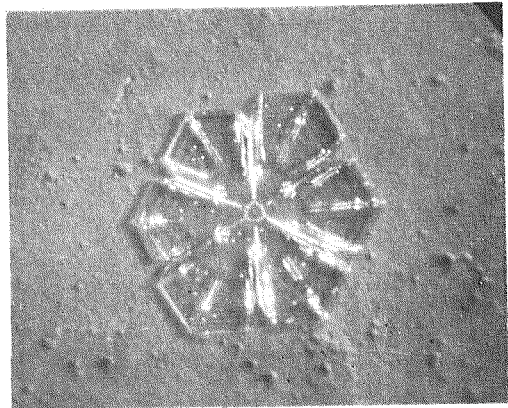

39 P1b Crystal with sectorlike branches $\times 30$

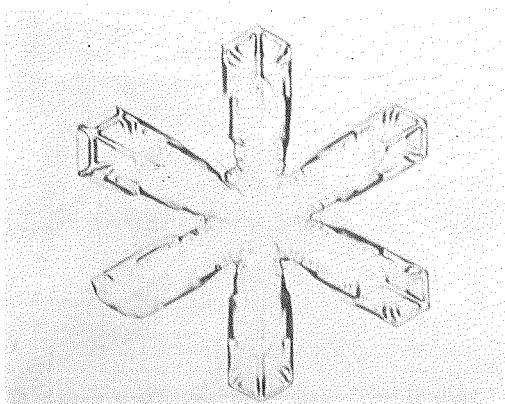

40 P1c Crystal with broad branches $\times 30.5$

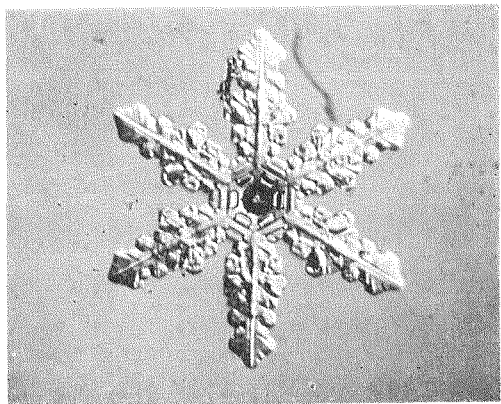

41 P1c Crystal with broad branches $\times 43.5$

Plate 8 Plane crystals; stellar, dendritic and fernlike crystals

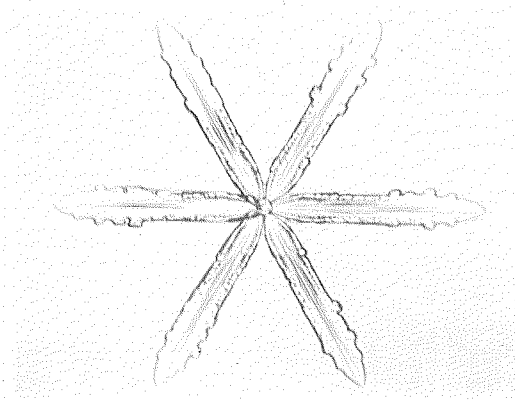

42 P1d Stellar crystal $\times 43.5$

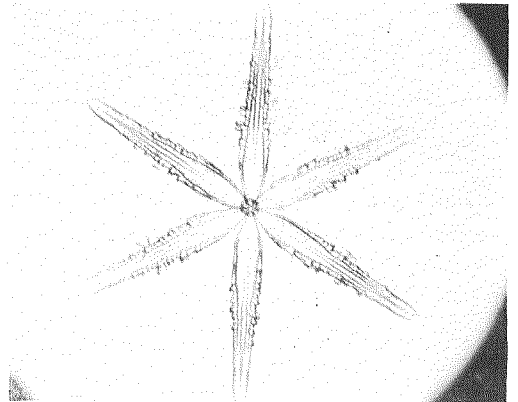

43 P1d Stellar crystal $\times 26$

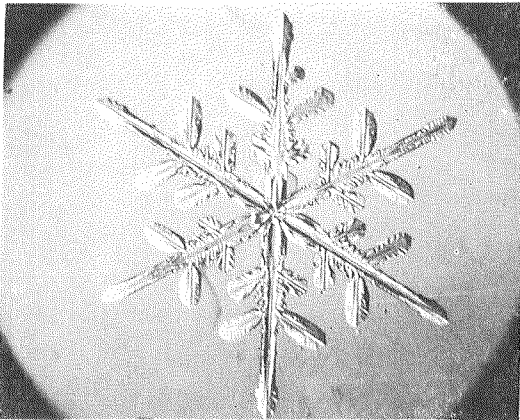

44 P1e Ordinary dendritic crystal $\times 23$

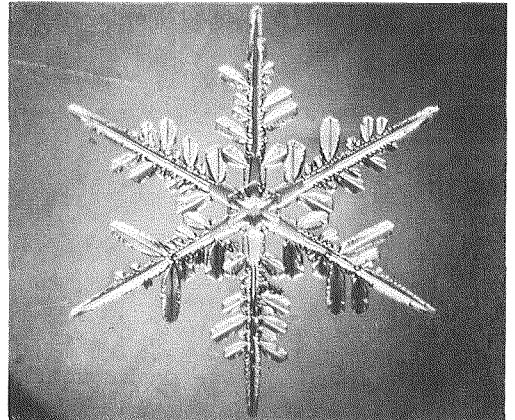

45 P1e Ordinary dendritic crystal $\times 28.5$

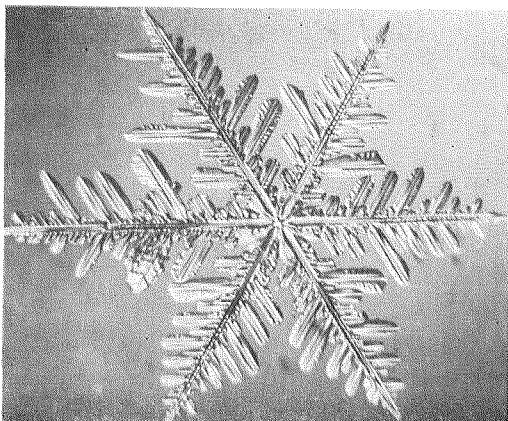

46 P1f Fernlike crystal $\times 19$

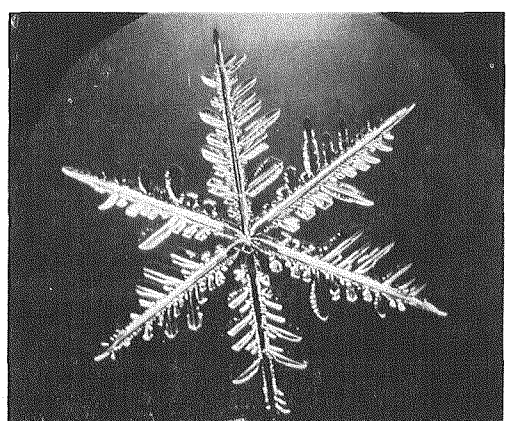

47 P1f Fernlike crystal $\times 22.5$

Plate 9 Plane crystals; regular crystals developed in one plane

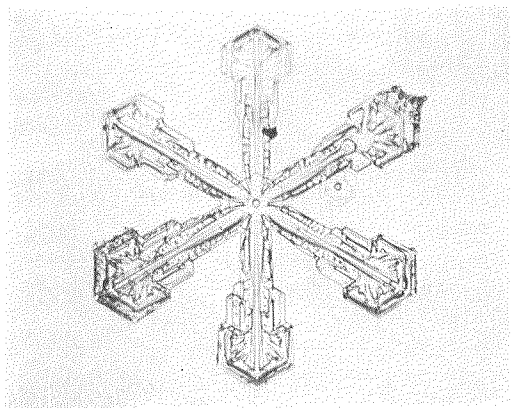

48 P2a Stellar crystal with plates at ends
× 32

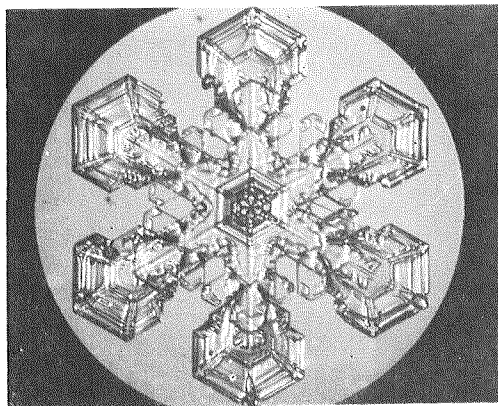

49 P2a Stellar crystal with plates at ends
× 25

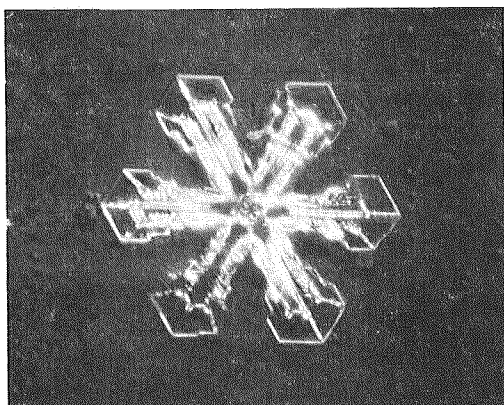

50 P2a Stellar crystal with plates at ends
× 17.5

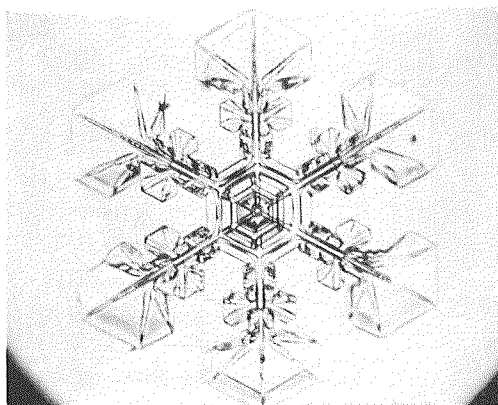

51 P2b Stellar crystal with sectorlike ends
× 28.5

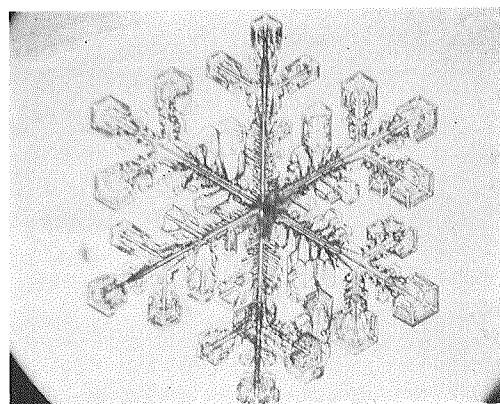

52 P2c Dendritic crystal with plates at ends
× 15

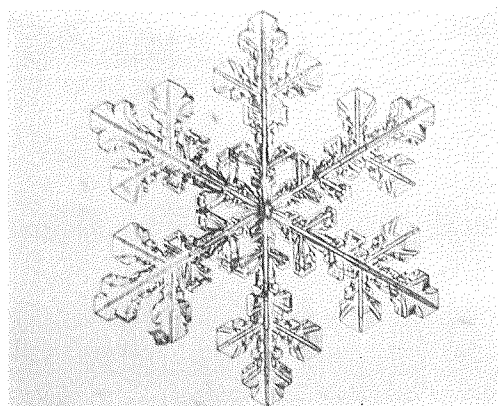

53 P2d Dendritic crystal with sectorlike ends
× 19

Plate 10 Plane crystals; plane crystals with extension of other form

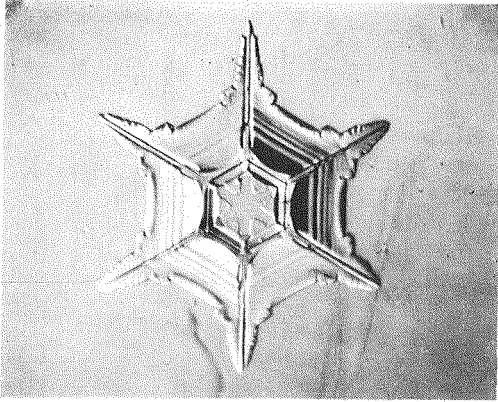

54 P2e Plate with simple extensions $\times 30$

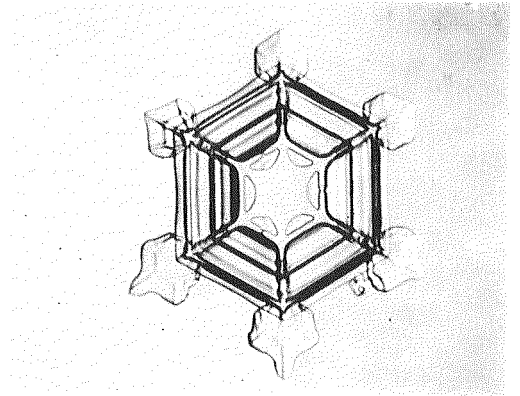

55 P2e Plate with simple extensions $\times 50$

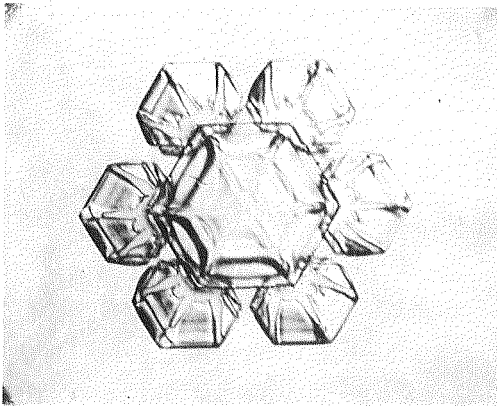

56 P2f Plate with sectorlike extensions
 $\times 29.5$

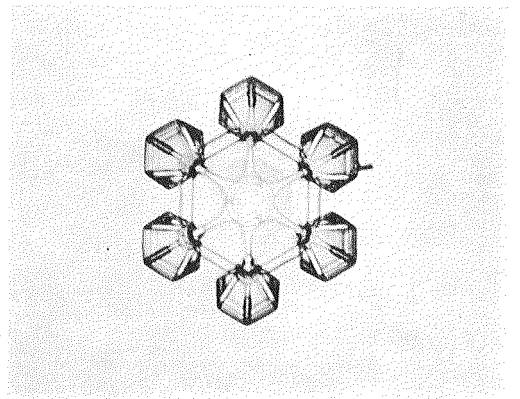

57 P2f Plate with sectorlike extensions
 $\times 57.5$

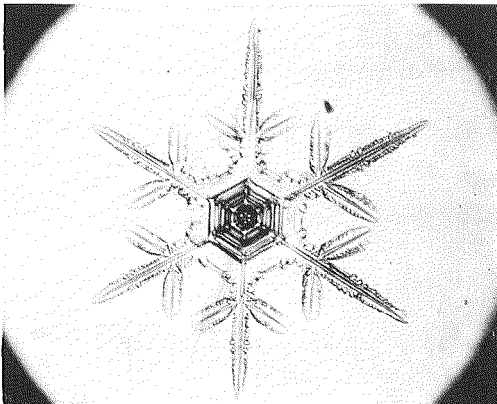

58 P2g Plate with dendritic extensions
 $\times 24$

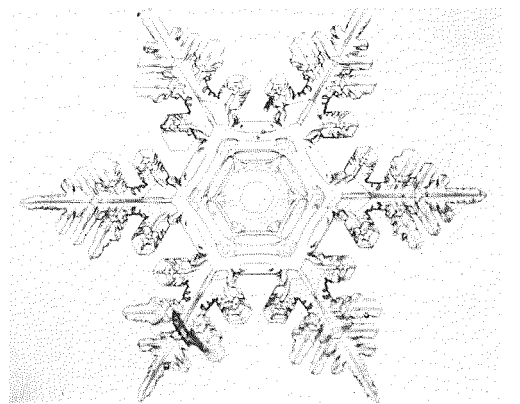

59 P2g Plate with dendritic extensions
 $\times 33$

Plate 11 Plane crystals; crystals with irregular number of branches

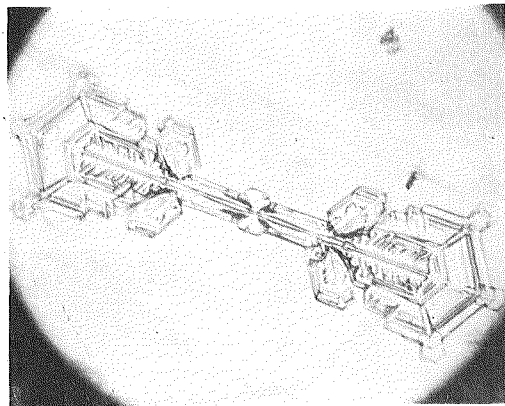

60 P2a Two-branched crystal × 25

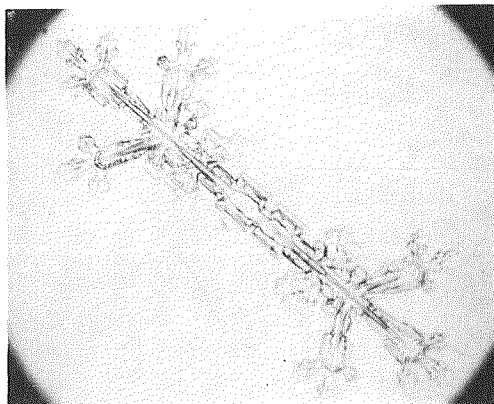

61 P2a Two-branched crystal × 35.5

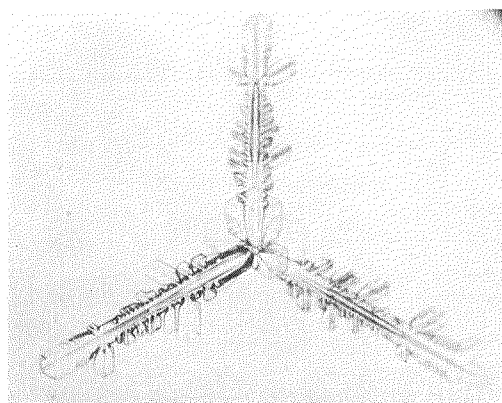

62 P2b Three-branched crystal × 34.5

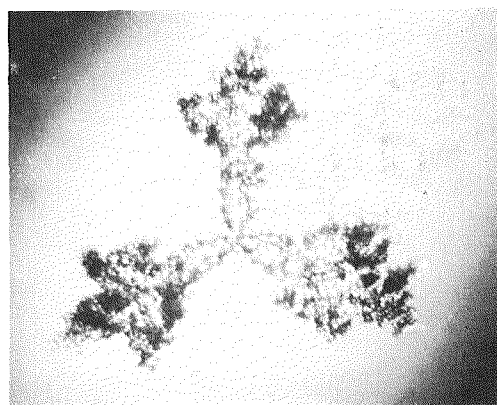

63 P2b Three-branched crystal × 30

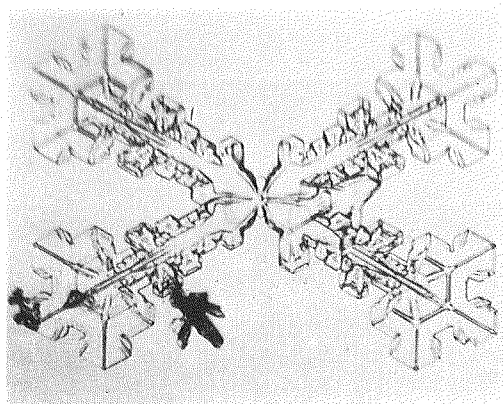

64 P2c Four branched crystal × 34.5

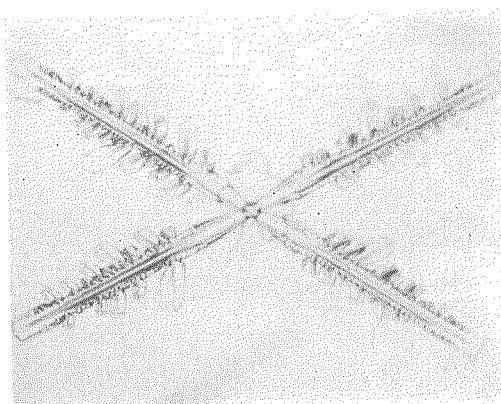

65 P2c Four-branched crystal × 27.5

Plate 12 Plane crystals; crystal with twelve branches, and malformed crystals

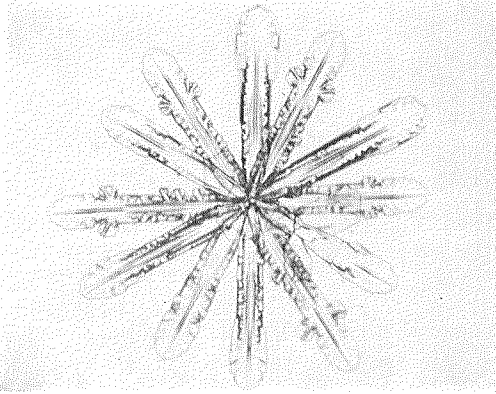

66 P3a Broad branch crystal with 12 branches $\times 37$

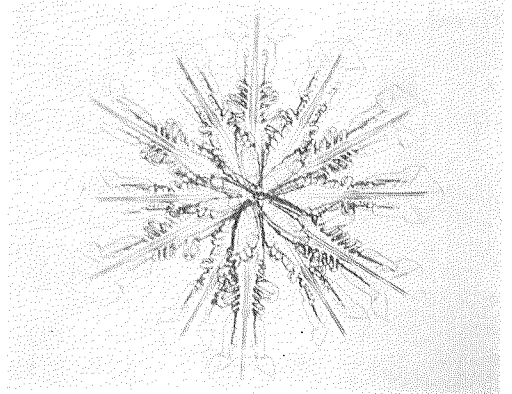

67 P3a Broad branch crystal with 12 branches $\times 32$

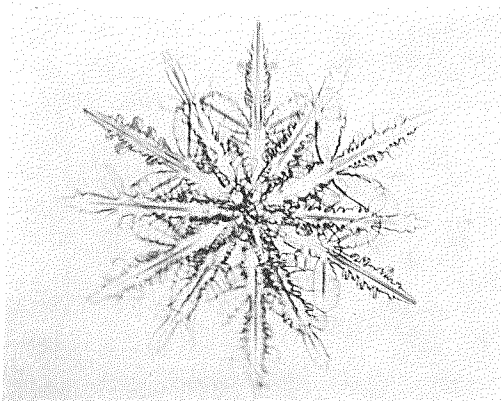

68 P3b Dendritic crystal with 12 branches $\times 28.5$

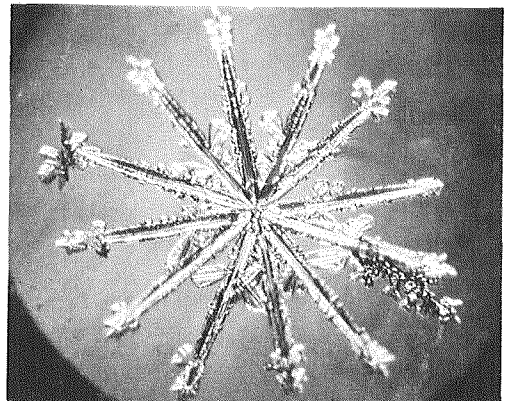

69 P3b Dendritic crystal with 12 branches $\times 25.5$

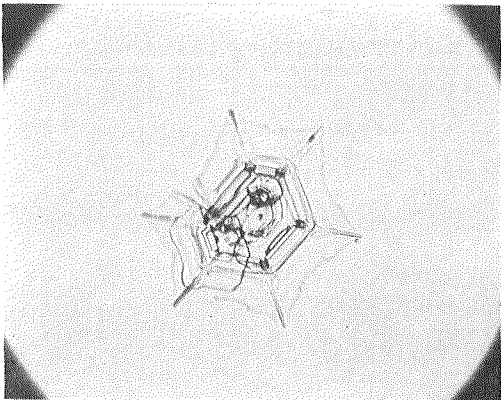

70 P4 Malformed crystal $\times 54$

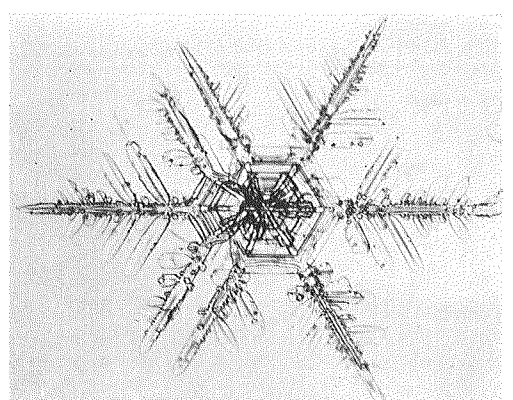

71 P4 Malformed crystal $\times 24$

Plate 13 Plane crystals; spatial assemblage of plane branches

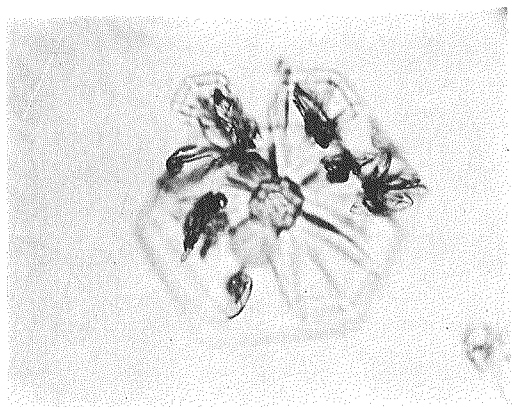

72 P5a Plate with spatial sectors $\times 51$

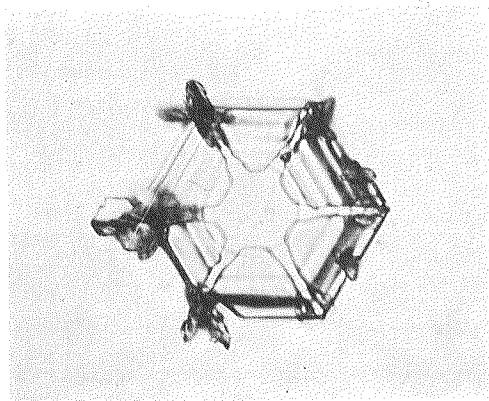

73 P5a Plate with spatial sectors $\times 73.5$

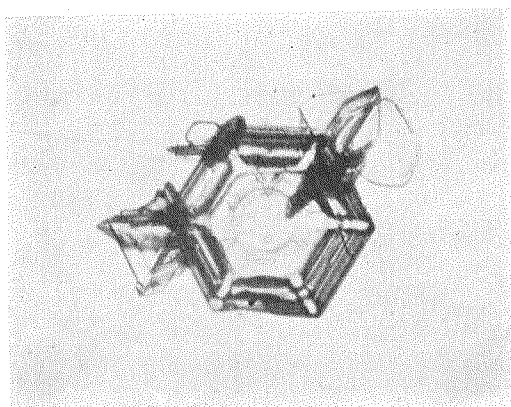

74 P5a Plate with spatial sectors $\times 62$

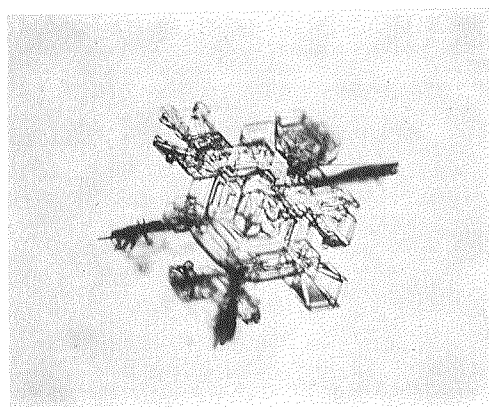

75 P5b Plate with spatial dendrites $\times 40$

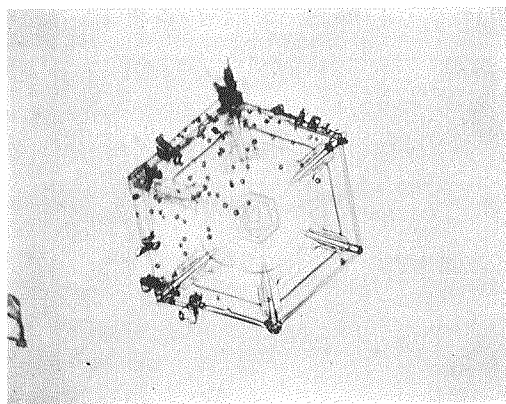

76 P5b Plate with spatial dendrites $\times 31.5$

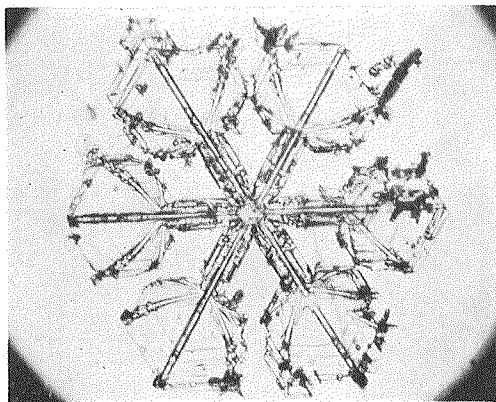

77 P5b Plate with spatial dendrites $\times 25.5$

Plate 14 Plane crystals; spatial assemblage of plane branches

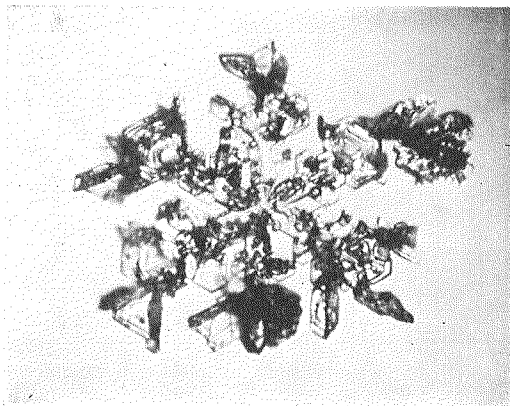

78 P5c Stellar crystal with spatial plates
× 69

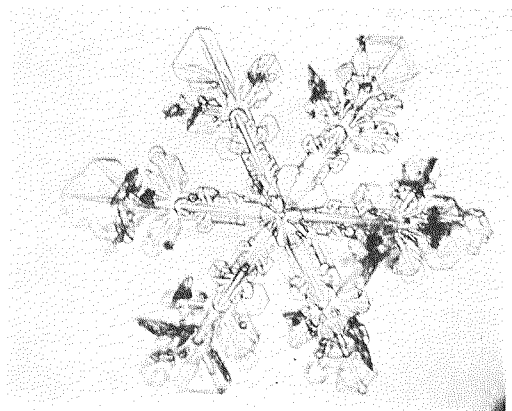

79 P5c Stellar crystal with spatial plates
× 32

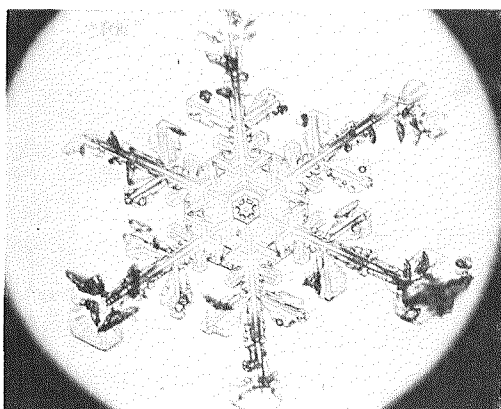

80 P5c Stellar crystal with spatial plates
× 23

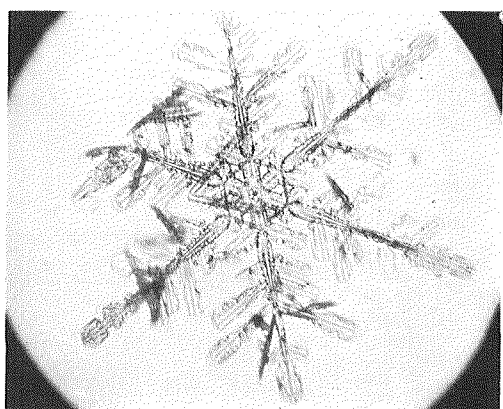

81 P5d Stellar crystal with spatial dendrites
× 12.5

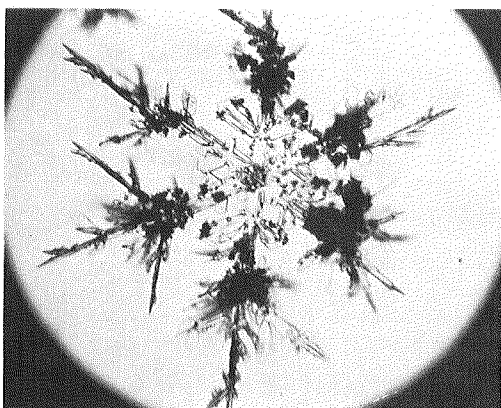

82 P5d Stellar crystal with spatial
dendrites
× 22

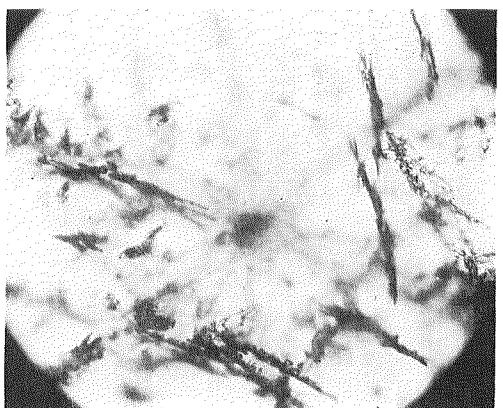

83 P5d Stellar crystal with spatial
dendrites
× 24

Plate 15 Plane crystals; radiating assemblage of plane branches

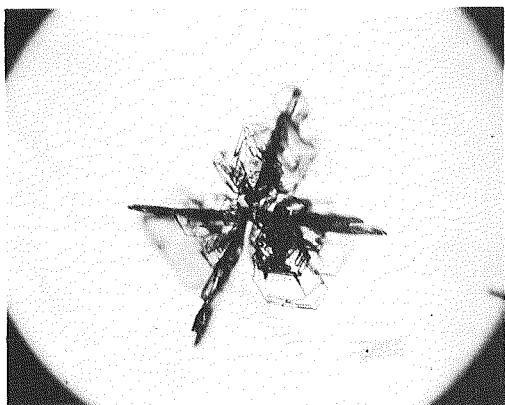

84 P6a Radiating assemblage of plates
× 25.5

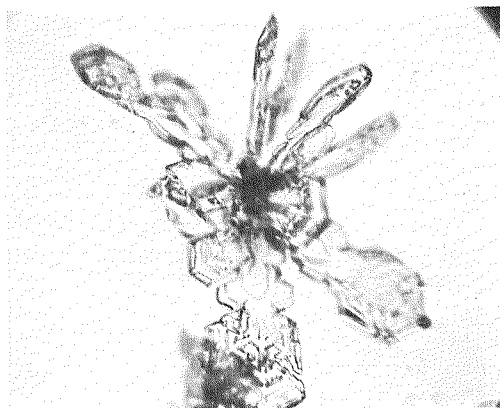

85 P5a Radiating assemblage of plates
× 43.5

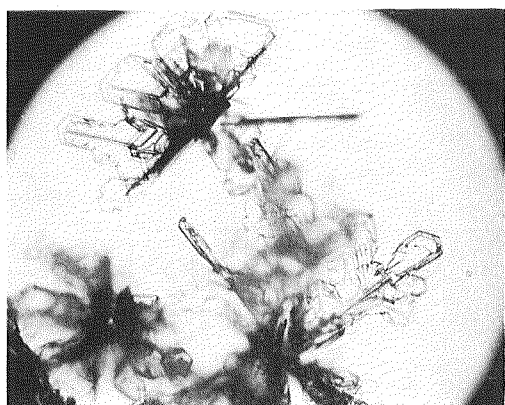

86 P6a Radiating assemblage of sectors
× 25

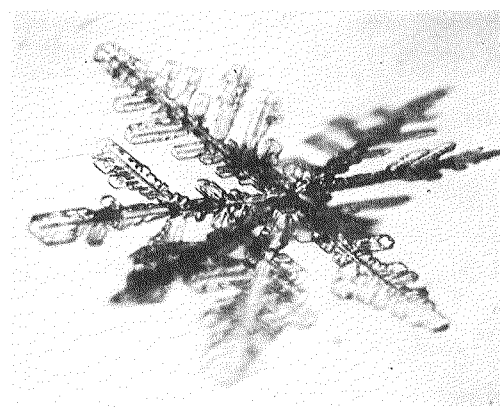

87 P6b Radiating assemblage of dendrites
× 28

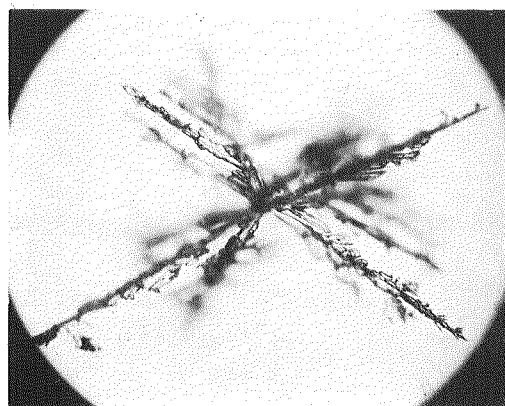

88 P6b Radiating assemblage of dendrites
× 24

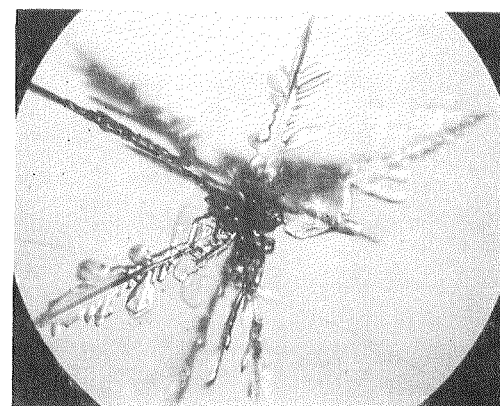

89 P6b Radiating assemblage of dendrites
× 30

Plate 16 Combination of column and plane crystals; column with plane crystals

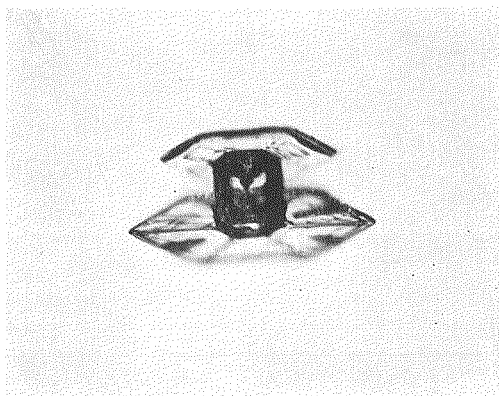

90 CP1a Column with plates $\times 40.5$

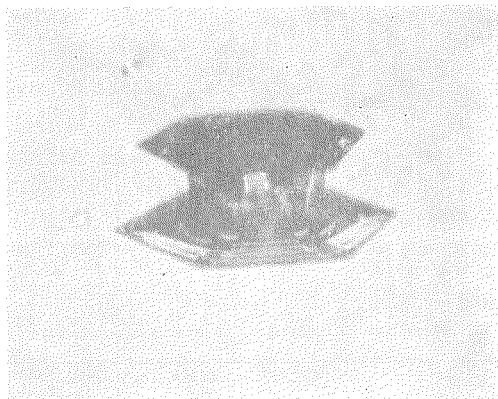

91 CP1a Column with plates $\times 70$

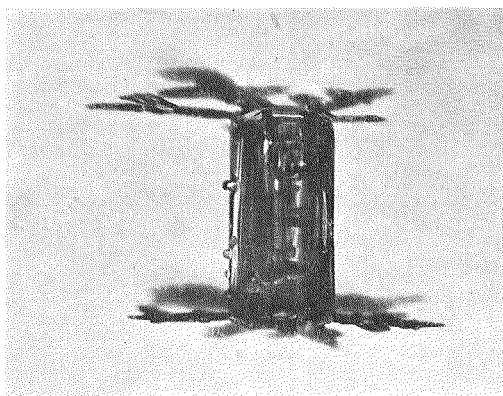

92 CP1b Column with dendrites $\times 52.5$

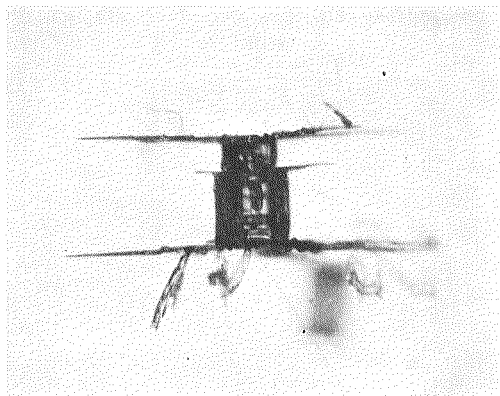

93 CP1b Column with dendrites $\times 36.5$

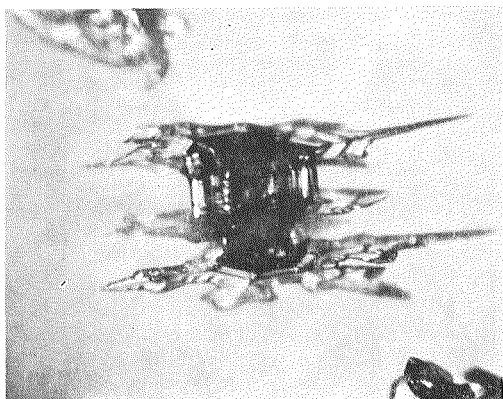

94 CP1c Multiple capped column $\times 49.5$

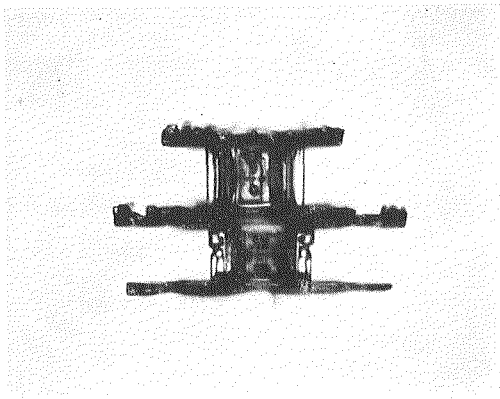

95 CP1c Multiple capped column $\times 38$

Plate 17 Combination of column and plane crystals; bullets with plane crystals

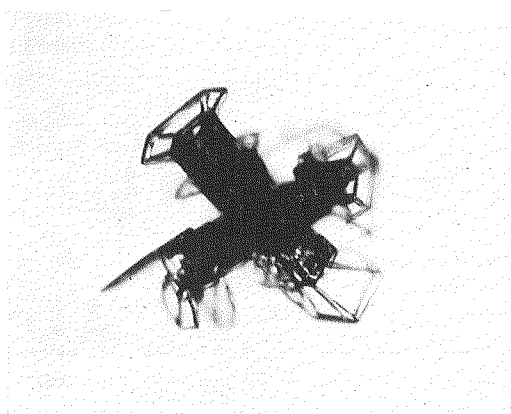

96 CP2a Bullets with plates $\times 39$

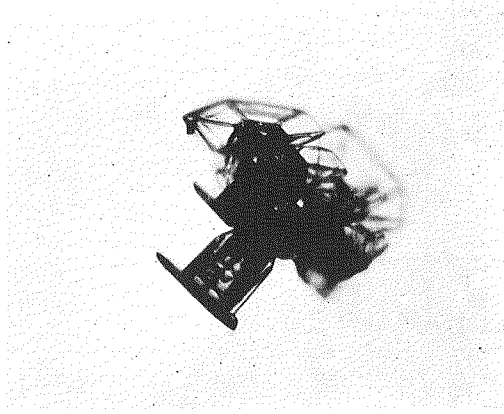

97 CP2a Bullets with plates $\times 38$

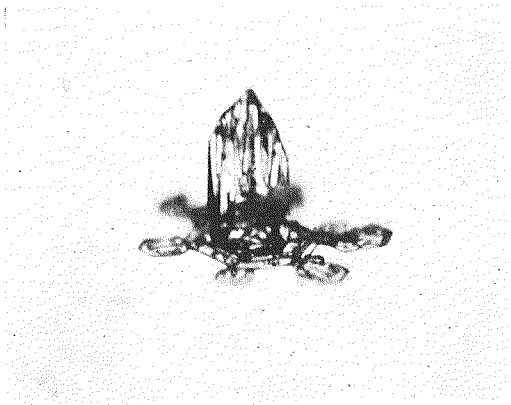

98 CP2b Bullet with dendrites $\times 47$

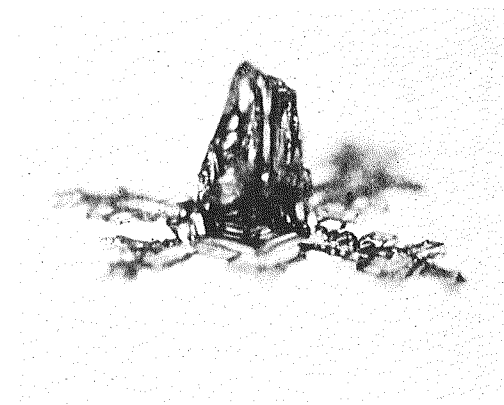

99 CP2b Bullet with dendrites $\times 48$

Plate 18 Combination of column and plane crystals; plane crystal with columns

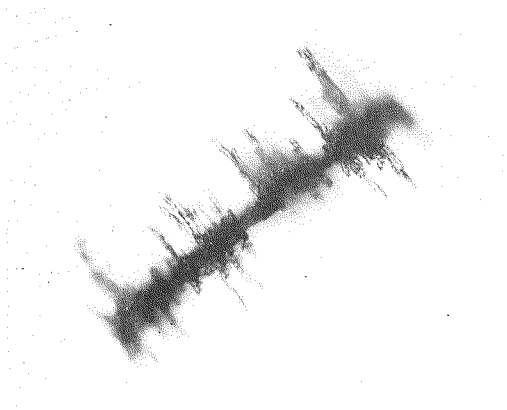

100 CP3a Stellar crystal with needles
(side view) $\times 15.5$

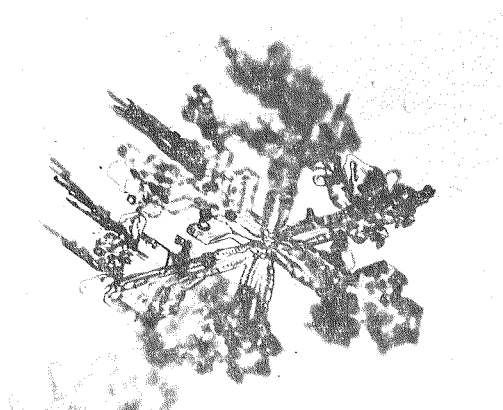

101 CP3a Stellar crystal with needles $\times 26$

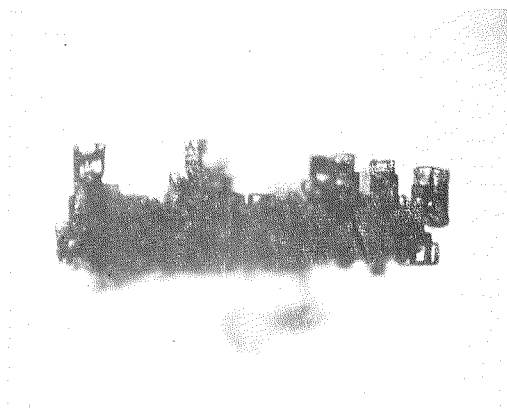

102 CP3b Stellar crystal with columns
(side view) $\times 37$

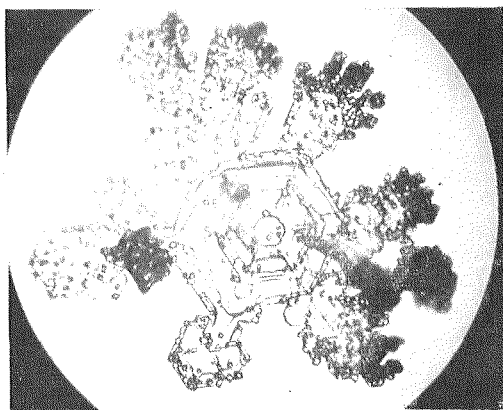

103 CP3b Stellar crystal with columns $\times 23$

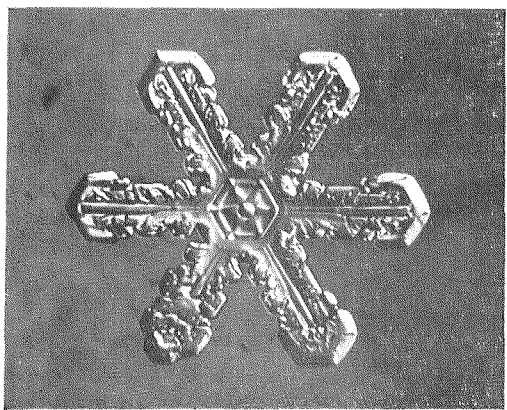

104 CP3c Stellar crystal with scrolls at ends
 $\times 40.5$

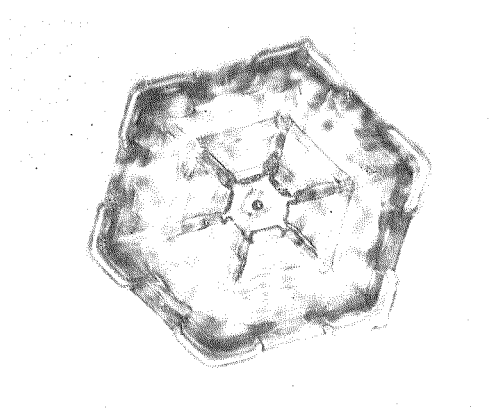

105 CP3d Plate with scrolls at ends $\times 35$

Plate 19 Columnar crystals with extended side planes

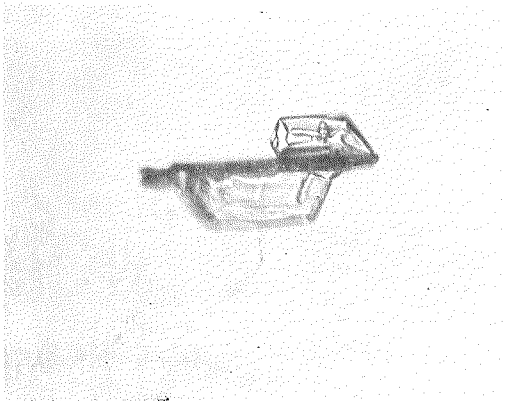

106 S1 Side planes $\times 53$

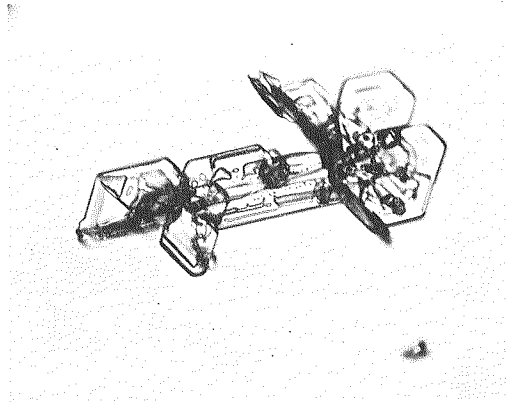

107 S1 Side planes $\times 47$

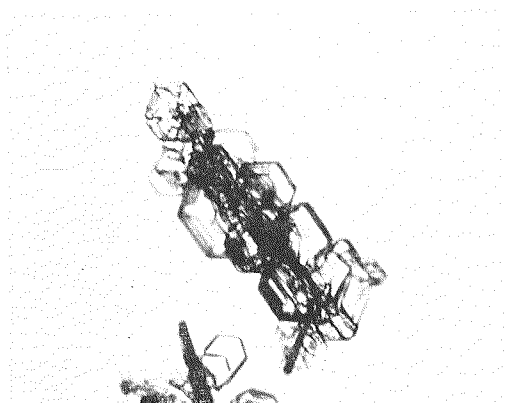

108 S2S calelike side planes $\times 48$

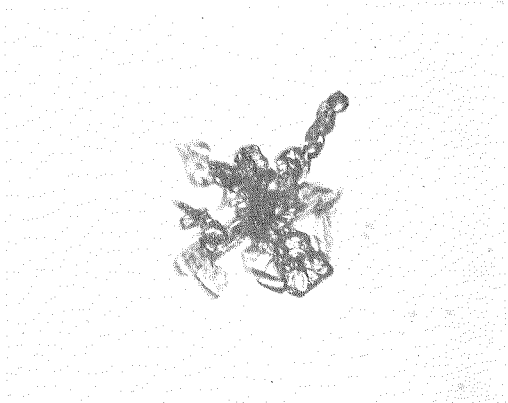

109 S2 Scalelike side planes $\times 52.5$

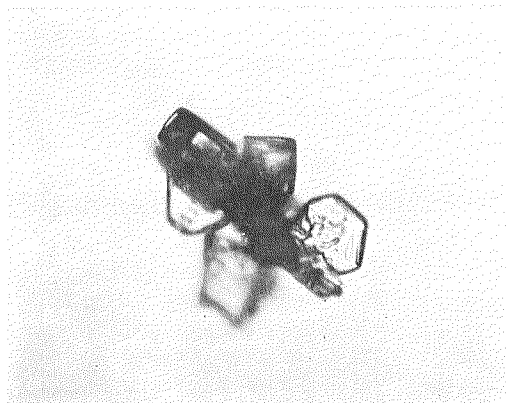

110 S3 Combination of side planes, bullets and columns $\times 65$

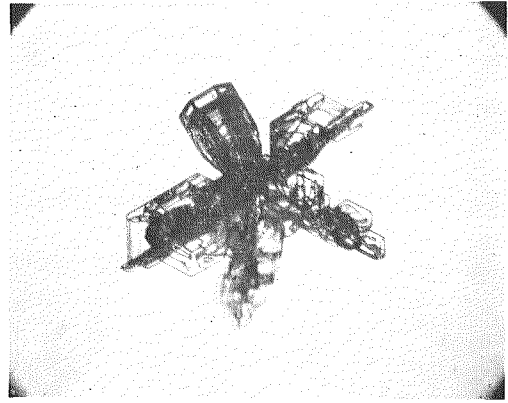

111 S3 Combination of side planes, bullets and columns $\times 37.5$

Plate 20 Rimed crystals; rimed Needles, columns and thick plates

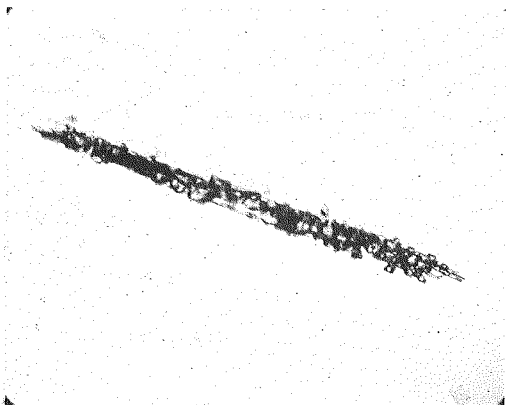

112 R1a Rimed needle $\times 30$

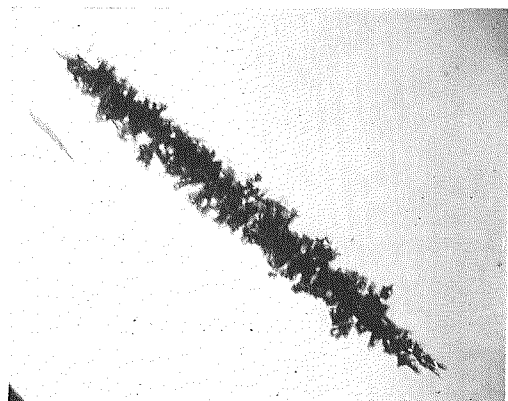

113 R1a Rimed needle $\times 30.5$

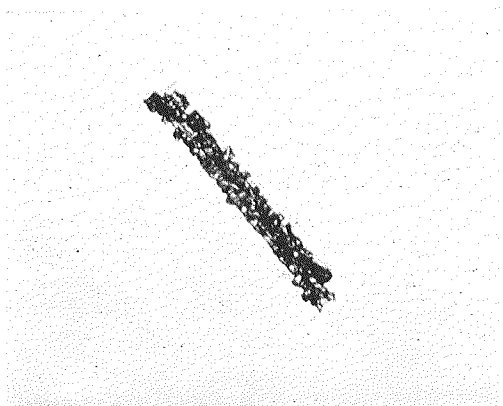

114 R1a Rimed sheath $\times 35$

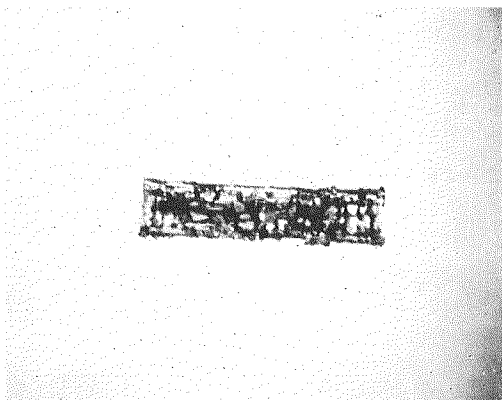

115 R1b Rimed column $\times 45.5$

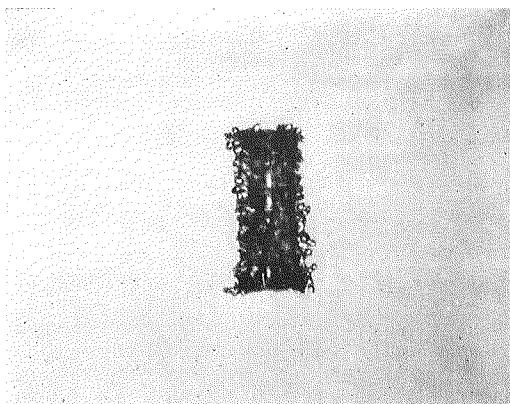

116 R1b Rimed column $\times 36$

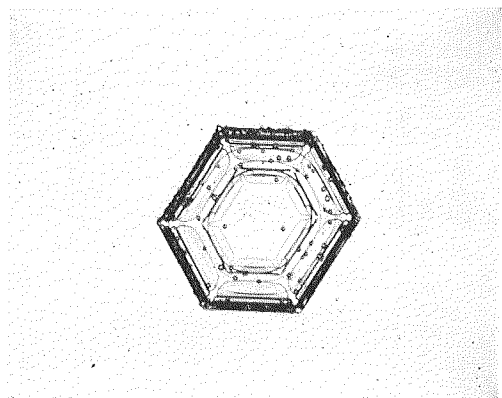

117 R1b Rimed thick plate $\times 34$

Plate 21 Rimed crystals; rimed plates, sectors and dendritic crystals

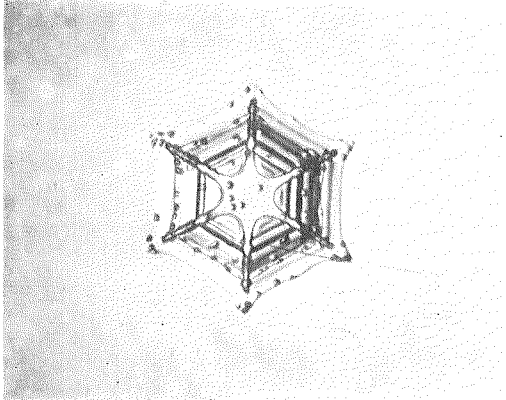

118 R1c Rimed plate $\times 34$

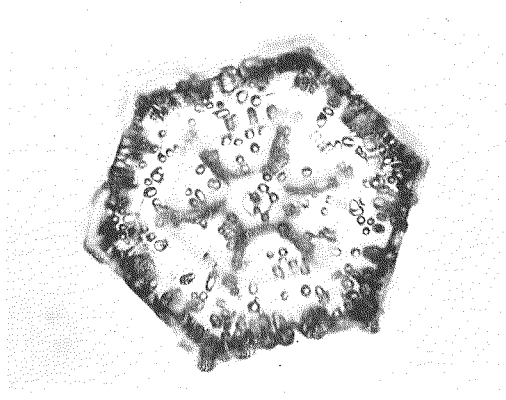

119 R1c Rimed plate $\times 35$



120 R1c Rimed sector $\times 37.5$

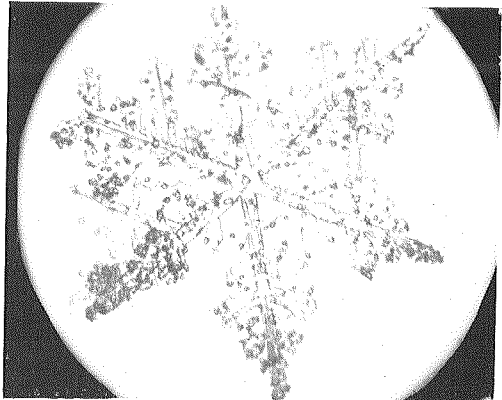

121 R1d Rimed stellar crystal $\times 21$

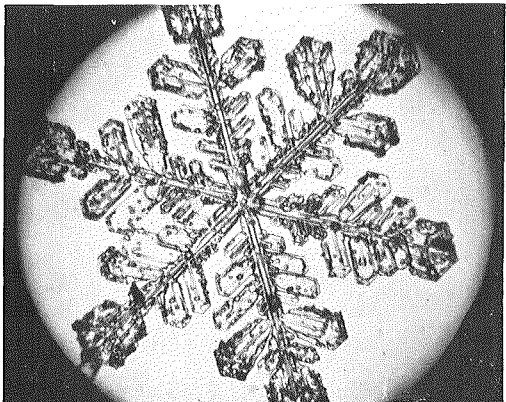

122 R1d Rimed stellar crystal $\times 13.5$

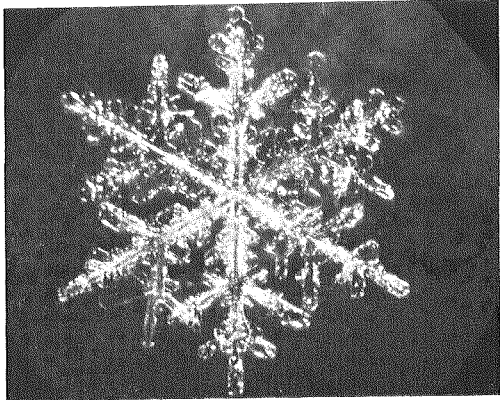

123 R1d Rimed stellar crystal $\times 28$

Plate 22 Rimed crystals; densely rimed crystals

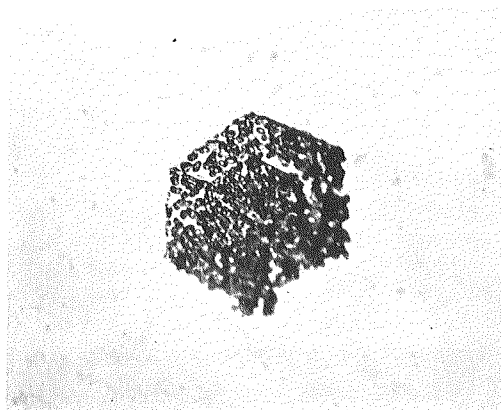

124 R2a Densely rimed plate $\times 42$

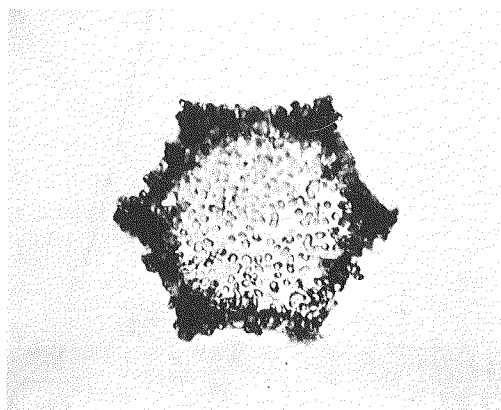

125 R2a Densely rimed plate $\times 43.5$

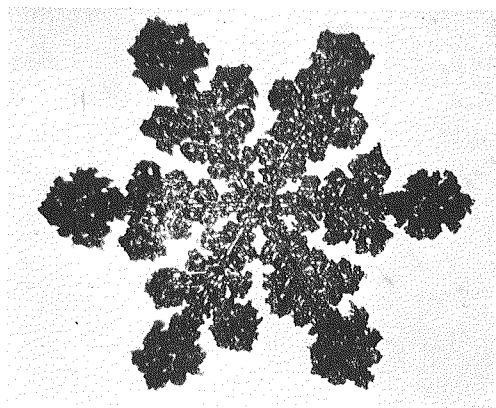

126 R2b Densely rimed stellar crystal $\times 18.5$

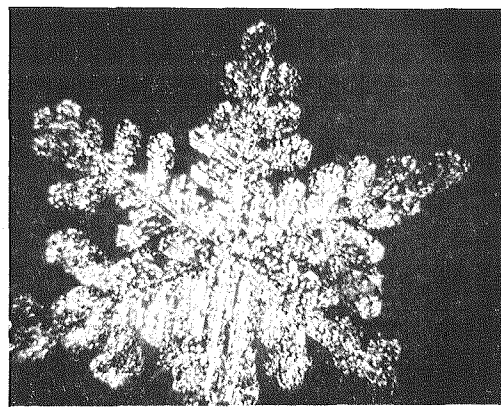

127 R2b Densely rimed stellar crystal $\times 15$

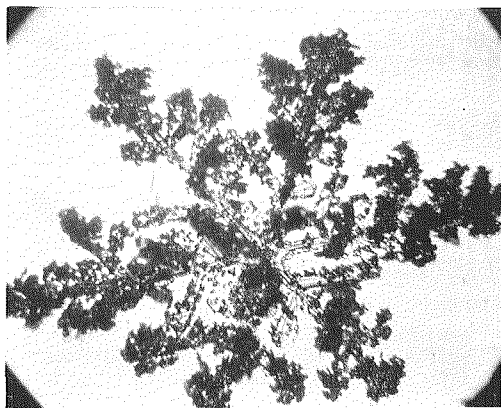

128 R2c Stellar crystal with rimed spatial branches $\times 14$

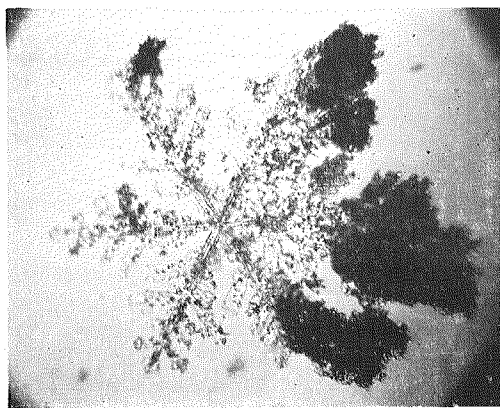

129 R2c Stellar crystal with rimed spatial branches $\times 12$

Plate 23 Rimed crystals; graupellike snow

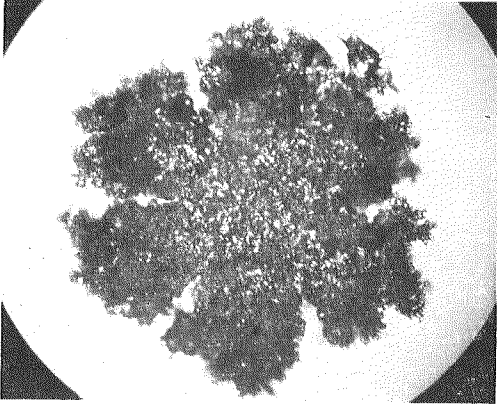

130 R3a Graupellike snow of hexagonal type $\times 25.5$

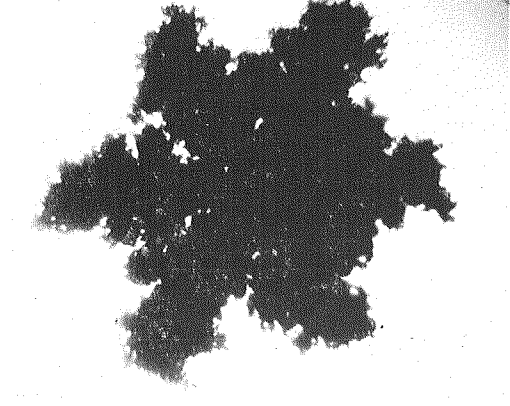

131 R3a Graupellike snow of hexagonal type $\times 17$

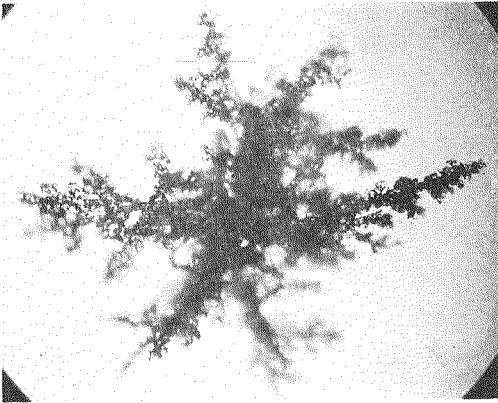

132 R3b Graupellike snow of lump type $\times 28.5$

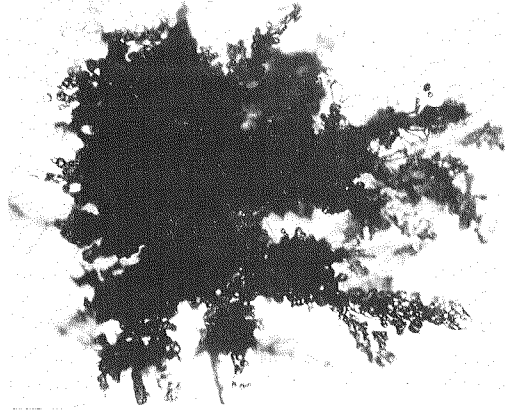

133 R3b Graupellike snow of lump type $\times 31$

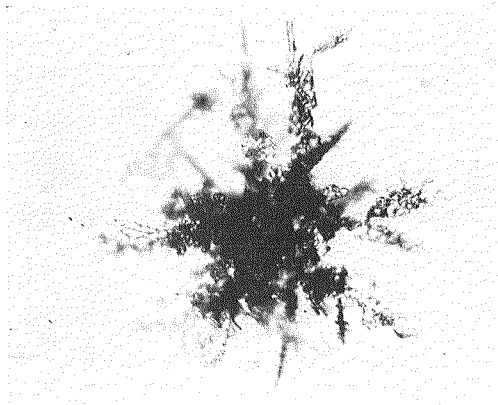

134 R3c Graupellike snow of nonrimed extensions $\times 31$

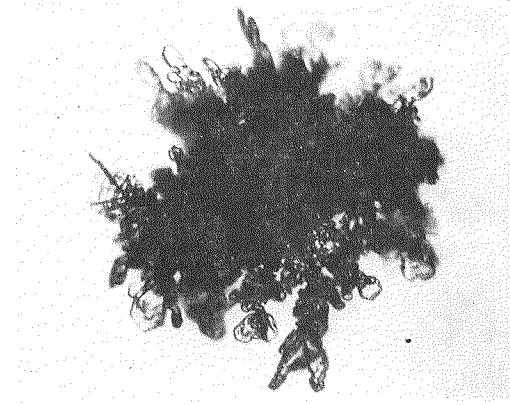

135 R3c Graupellike snow of nonrimed extensions $\times 26$

Plate 24 Rimed crystals; graupel

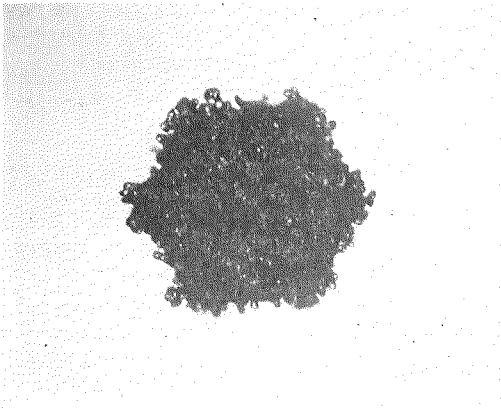

136 R4a Hexagonal graupel $\times 28$

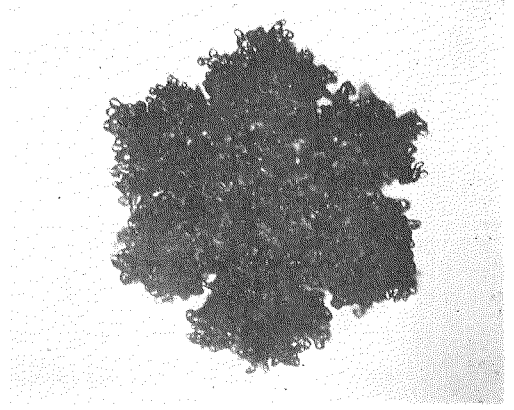

137 R4a Hexagonal graupel $\times 26$

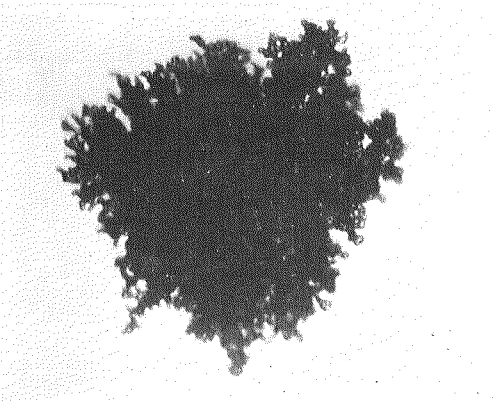

138 R4b Lump graupel $\times 33$

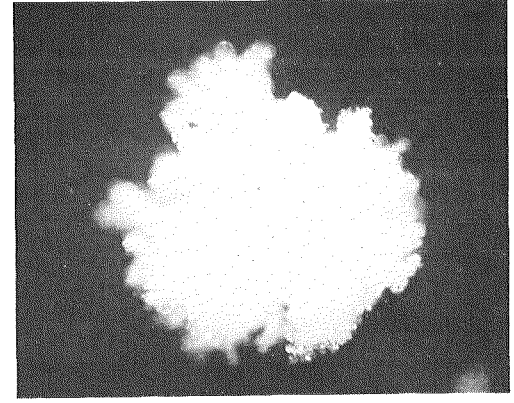

139 R4b Lump graupel $\times 15$

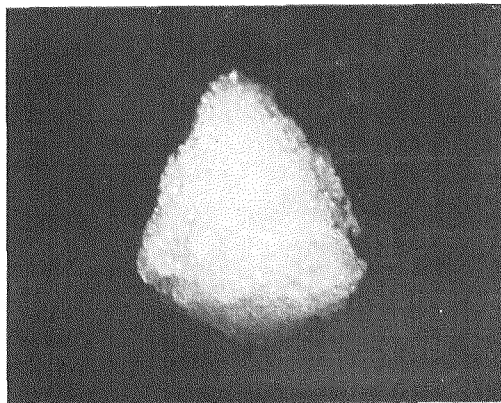

140 R4c Conelike graupel $\times 17$

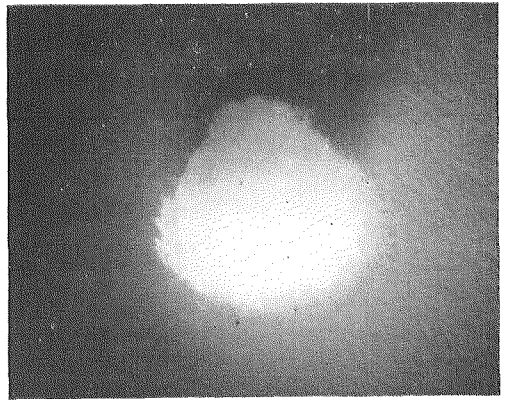

141 R4c Conelike graupel $\times 6$

Plate 25 Irregular snow crystals; ice particles, rimed particles, broken pieces
and miscellaneous

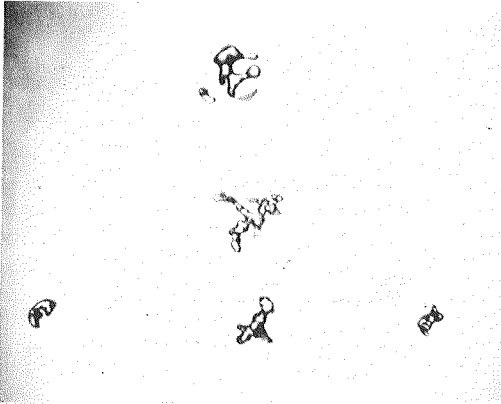

142 I1 Ice particles $\times 27$

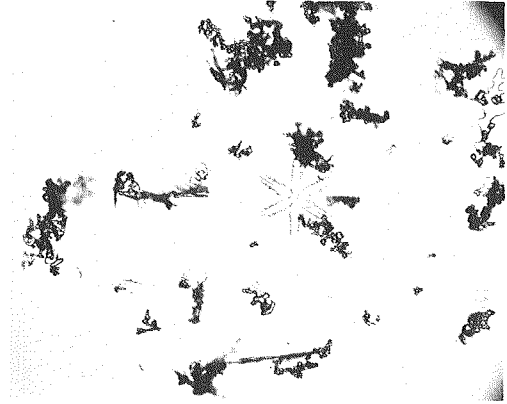

143 I2 Rimed particles $\times 17$



144 I3a Broken branch $\times 32$

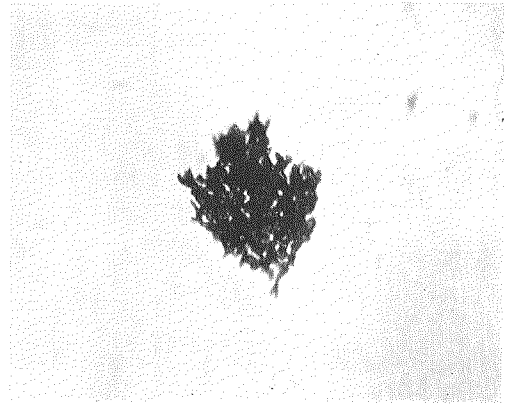

145 I3b Rimed broken branch $\times 37.5$

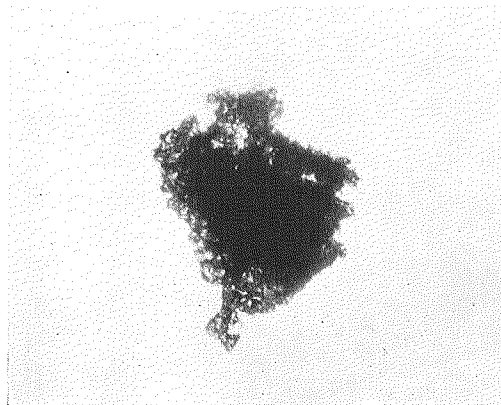

146 I3b Rimed broken branch $\times 33$

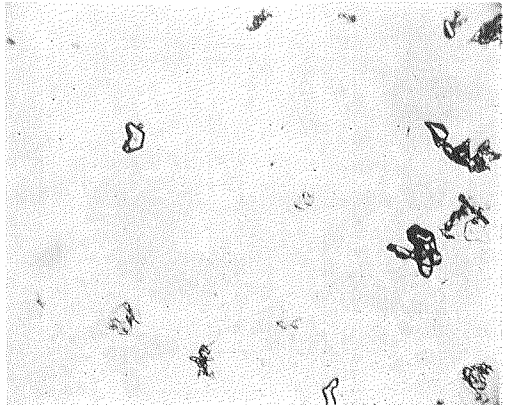

147 I4 Miscellaneous $\times 18$

Plate 26 Germs of snow crystals

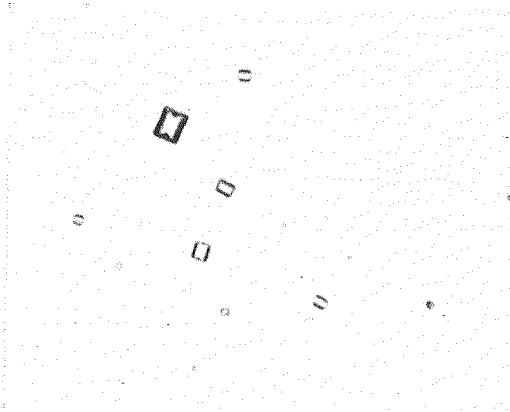

148 G1 Minute columns $\times 162$

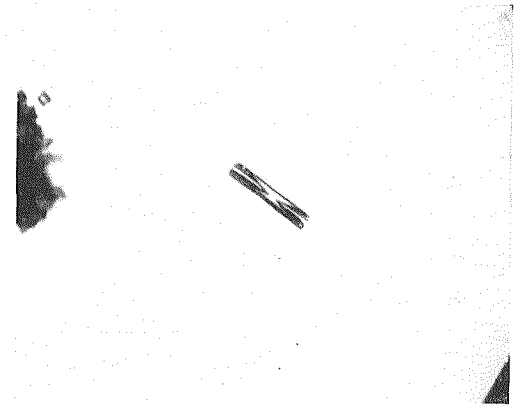

149 G1 Minute column $\times 39.5$

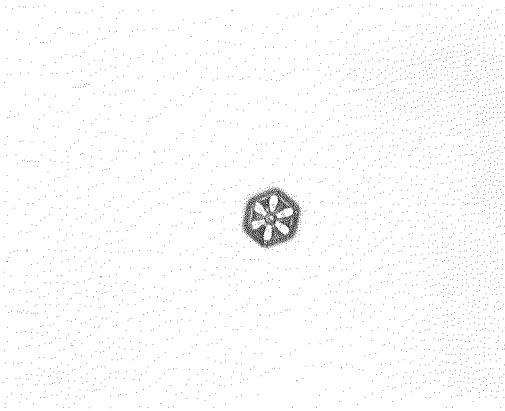

150 G2 Germ of skelton form $\times 63.5$



151 G2 Germ of skelton form $\times 70.5$

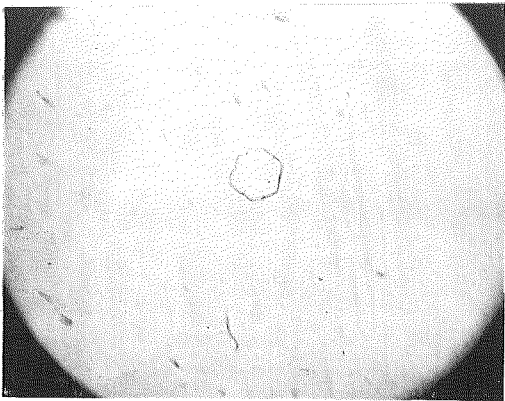

152 G3 Minute hexagonal plate $\times 13.5$

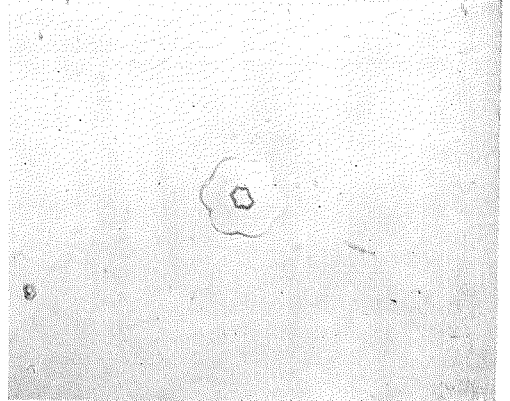

153 G3 Minute hexagonal plate $\times 54$

Plate 27 Germs of snow crystals

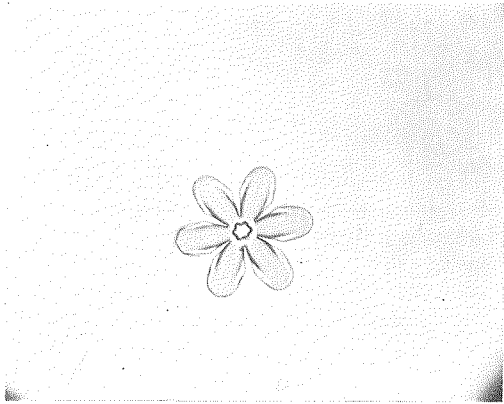

154 G4 Stellar germ $\times 43.5$

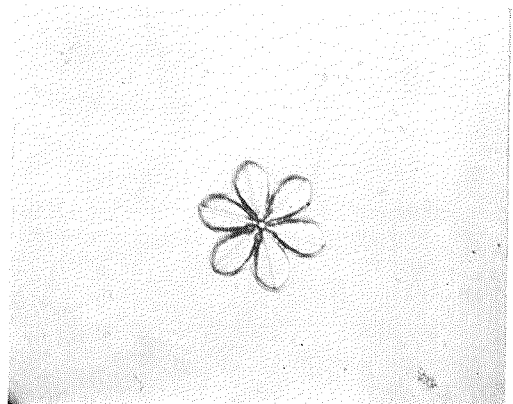

155 G4 Stellar germ $\times 54.5$

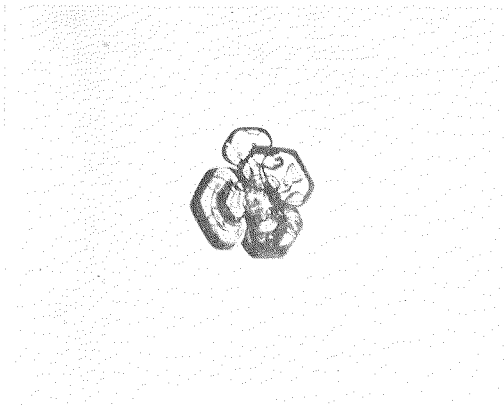

156 G5 Assemblage of minute plate $\times 56$

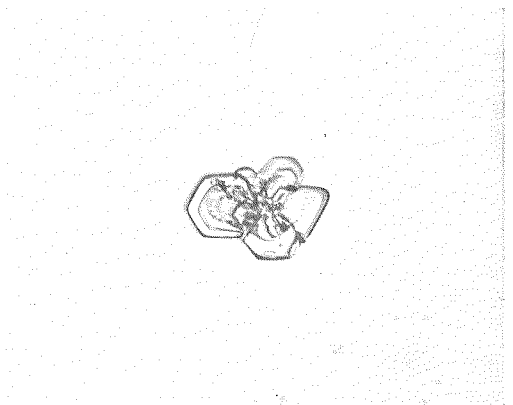

157 G5 Assemblage of minute plate $\times 46.5$

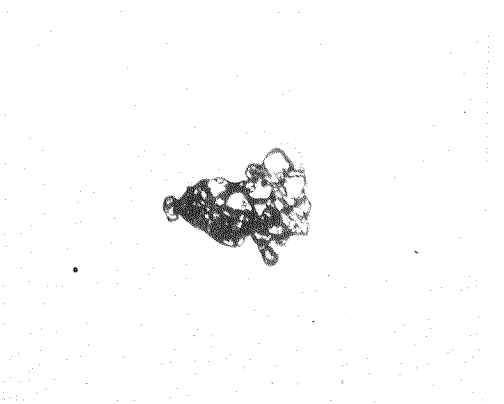

158 G6 Irregular germ $\times 41$

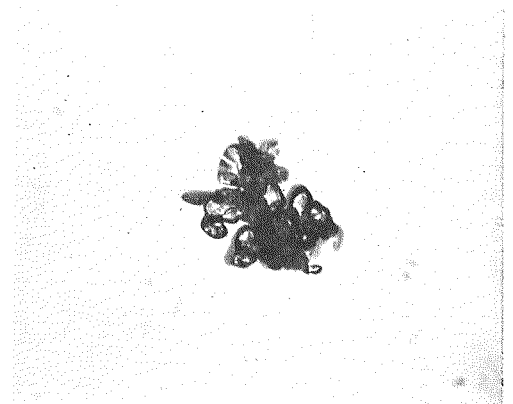

159 G6 Irregular germ $\times 62$