

**1-inch Microphone Type 40EN  
Instructions for Changing the O-rings**

Revision 08 10 2003

## 1-inch Microphone Type 40EN Instructions for Changing the O-rings



*Pressure Microphone Type 40EN.*

*Left: with protection grid*

*Right: 64-AA configuration for NBS 9-A couplers*

## Changing O-rings On the Type 40EN

When changing O-rings **do not remove the protection grid.**

The standard Type 40EN as delivered is front vented and fitted with the OR0774 O-ring as shown in Fig. 1.1. The other O-ring GR5003 is also supplied with the Type 40EN.

To change the O-ring, unscrew the locking ring (which is engraved with "Type 40EN" and serial number, see diagrams) using the special key GR0603 provided.

For rear venting, remove the OR0774 and fit the OR5003 as shown in Fig 1.2.

For non venting, fit both the OR0774 and OR5003 as shown in Fig 1.3.

Note: In the non-venting case, before air transportation place the microphone in an air-tight container or slacken the locking ring engraved with "Type 40EN" and serial number.

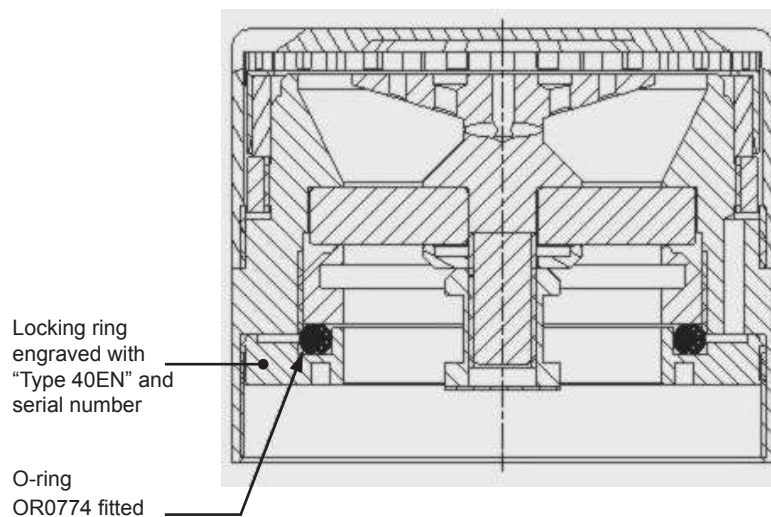

Fig. 1.1 Front vented standard on delivery  
O-ring OR0774 fitted

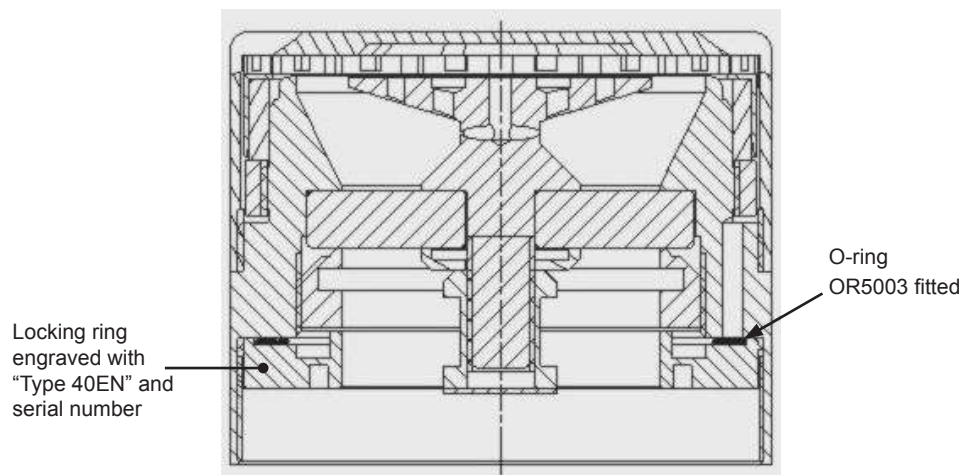
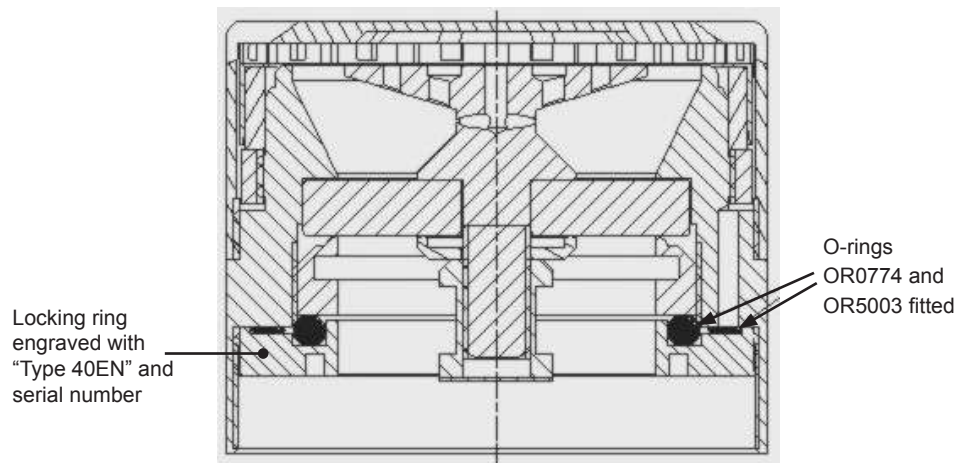

Fig. 1.2 Rear vented  
O-ring OR5003 fitted



*Fig. 1.3 Non vented  
O-rings OR0774 and OR5003 fitted*

### Venting Paths

Figs 1.5 and 1.6 show the two venting paths of the Type 40EN. In both cases the normal protection grid is fitted. The encircled numbers indicate:

- ① behind diaphragm
- ② front of diaphragm
- ③ preamplifier-contact area

Note: if the microphone cartridge is fitted with its coupler adapter RA0074 (Fig. 1.4) instead of the normal protection grid, the sealing ring (tucked under the lip of the RA0074) should be removed from the coupler adapter to maintain front venting.



*Fig. 1.4 Type 40EN fitted with its coupler adapter RA0074*

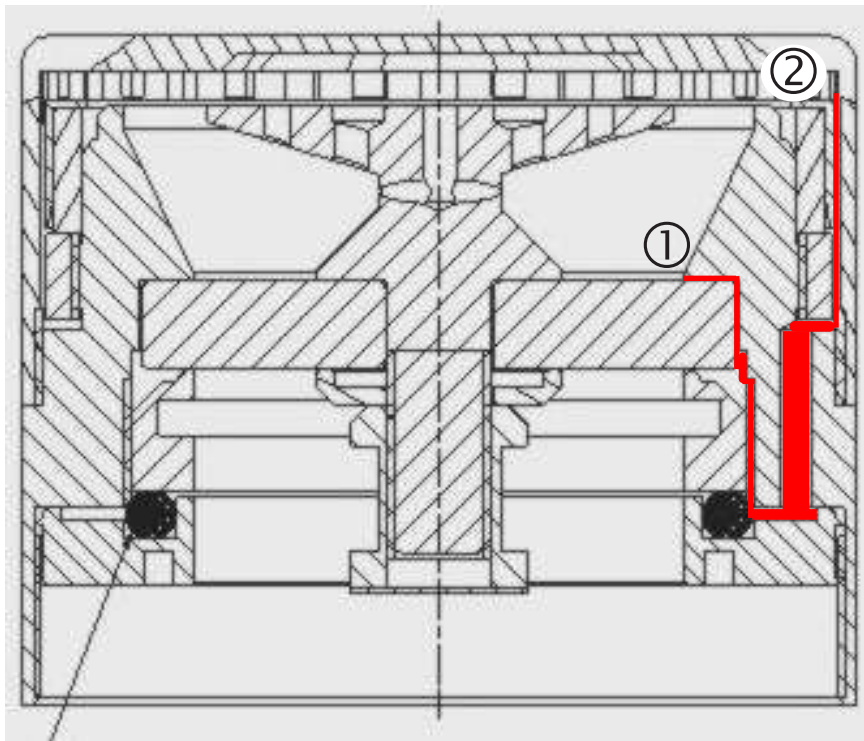

Fig. 1.5 Showing path for front venting

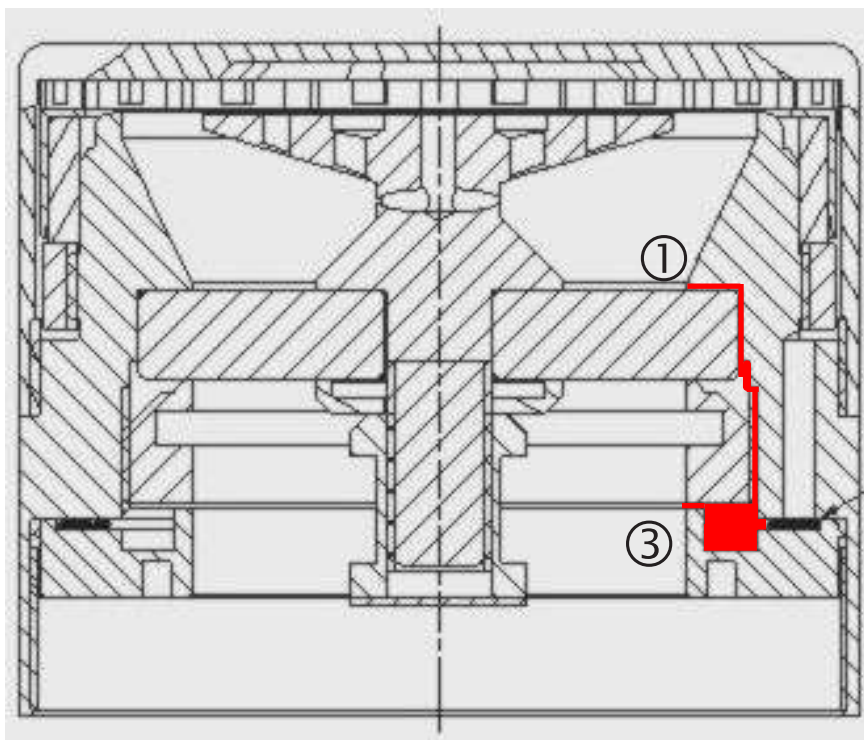

Fig. 1.6 Showing path for rear venting